



SOUTHERN PINE HEADERS & BEAMS

Size Selection and Allowable Load Tables for
Southern Pine Lumber and Glued Laminated Timber



SouthernPine.com



Foreword

For more than 300 years, Southern Pine headers and beams have framed millions of windows and doors, and supported just as many floor joist systems. This one-of-a-kind publication provides an easy method for selecting the proper Southern Pine header or beam for its intended application.

This brochure provides *Size Selection* and *Allowable Load Tables* for Southern Pine lumber and glued laminated timber (glulam) headers and beams. These tables will aid architects, engineers, contractors and other professionals engaged in designing and building residential and commercial structures in selecting the proper size of header or beam for the job.

The Southern Pine lumber reference design values used in developing the tables in this brochure are new design values effective June 1, 2013; they are from *SPIB Standard Grading Rules for Southern Pine Lumber, 2002 Edition with Supplements*, published by the Southern Pine Inspection Bureau (SPIB). The glued laminated timber design values are from *ANSI 117-10, Standard Specifications for Structural Glued Laminated Timber of Softwood Species*, and *Glulam Design Properties and Layup Combinations* published by APA -The Engineered Wood Association. The design values have been adjusted according to the *2012 National Design Specification® for Wood Construction (NDS®)*, published by the American Wood Council (AWC). Beam sizes or allowable load capacities have been determined using standard engineering formulas for beams supporting uniformly distributed loads. Values tabulated represent the most limiting of four design parameters – bending (flexure), deflection, compression perpendicular-to-grain and shear parallel-to-grain (horizontal shear).

These tables are ideal for professionals who will apply the required technical knowledge. For the *Size Selection Tables*, the user must determine the required load conditions, clear opening, and span of the trusses or other members framing into the header or beam. For the *Allowable Load Tables*, the user must determine the load in pounds per lineal foot (plf) the header or beam is required to carry.



6660 Riverside Drive, Suite 212 • Metairie, LA 70003
504/443-4464 • FAX: 504/443-6612
info@southernpine.com

SFPA is a nonprofit trade association
that has represented manufacturers of
Southern Pine lumber since 1915.

SouthernPine.com

Contents

Building with Wood	1
Index to Tables	1
Southern Pine Advantages	2
Assumptions for Table Development	2
Identification	5
Fabricating Multiple-Member Headers and Beams	5
Typical Connections	6
Size Selection Tables	7
Window, Door & Garage Door Headers – Supporting Roof Loads Only	8
Window, Door & Garage Door Headers – Supporting Roof, Wall & Floor Loads	12
Floor Girder Beams	16
Floor Edge Beams	18
Roof Ridge Beams	19
Allowable Load Tables	23
Allowable Floor Loads	24
Allowable Roof Loads	29
Why Wood?	IBC
Additional Resources	Back Cover



Southern Forest Products Association does not develop design values for either lumber or glued laminated timber. Accordingly, SFPA does not warrant the design values on which these tables are based, and assumes no liability for damage caused or contributed to by the use of such design values. In addition, SFPA and its members have no knowledge of the loads, spans, materials used, quality of workmanship, professional competence of the users, and other factors involved in specifying headers or beams for any given project; and accordingly, cannot, and do not, represent or warrant the performance in use of headers or beams incorporated into any particular construction project, and disclaim liability for injury or damage caused by the failure of a header or beam in use.





Building with Wood

Throughout history, wood has found favor as a building material due to its strength, economy, workability, beauty and durability. Wood-frame buildings are economical to build, heat and cool, and provide maximum comfort to occupants. Wood construction is readily adaptable to traditional, contemporary and the most cutting-edge building styles. Its architectural possibilities are limitless and its durability spans the centuries.

Wood building materials are good for the environment, too. Wood is a renewable, sustainable resource that is manufactured in energy-efficient processes that optimize use of renewable energy sources. In fact, in a comparison of fossil fuel consumption associated with the materials for three floor systems – wood, concrete and steel – the wood joist floor required the least amount of fossil fuel energy.

CONSUMPTION OF FOSSIL FUELS (MJ/FT²) ASSOCIATED WITH THREE FLOOR DESIGNS

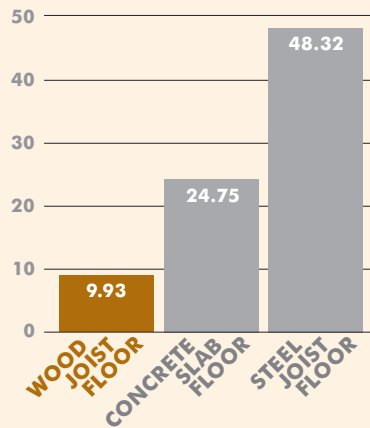

Note:

One megajoule (MJ) is equivalent to 0.27778 kilowatt hours or 947.8 BTUs.

Source: Consortium for Research on Renewable Industrial Materials (CORRIM)

Index to Size Selection Tables

Table Number	Grade	Live or Ground Snow Load (psf)	Dead Load (psf)	Load Duration Factor, C _D	See Page
Window, Door & Garage Door Headers – Supporting Roof Loads Only					
1	All	30	10	1.15	8
2	All	40	10	1.15	9
3	All	50	10	1.15	9
4	All	70	10	1.15	10
5	All	20	10	1.25	10
6	All	20	20	1.25	11
Window, Door & Garage Door Headers – Supporting Roof, Wall & Floor Loads					
7	All	30	10	1.15	12
8	All	40	10	1.15	13
9	All	50	10	1.15	13
10	All	70	10	1.15	14
11	All	20	10	1.25	14
12	All	20	20	1.25	15
Floor Girder Beams					
13	All	40	10	1.00	16
Floor Edge Beams					
14	All	40	10	1.00	18
Roof Ridge Beams					
15	All	30	10	1.15	19
16	All	40	10	1.15	20
17	All	50	10	1.15	20
18	All	70	10	1.15	21
19	All	20	10	1.25	21
20	All	20	20	1.25	22

Index to Allowable Load Tables

Table Number	Grade	Total Load Deflection Limit	Live Load Deflection Limit	Load Duration Factor, C _D	See Page
Allowable Floor Loads (plf)					
21	No.1	240	360	1.00	24
22	No.2	240	360	1.00	25
23	No.3	240	360	1.00	25
24	24F-1.7E	240	360	1.00	26
25	24F-1.7E	240	360	1.00	27
26	24F-1.8E	240	360	1.00	28
Allowable Roof Loads (plf)					
27	No.1	180	240	1.15	29
28	No.2	180	240	1.15	30
29	No.3	180	240	1.15	30
30	24F-1.7E	180	240	1.15	31
31	24F-1.7E	180	240	1.15	32
32	24F-1.8E	180	240	1.15	33
33	No.1	180	240	1.25	34
34	No.2	180	240	1.25	35
35	No.3	180	240	1.25	35
36	24F-1.7E	180	240	1.25	36
37	24F-1.7E	180	240	1.25	37
38	24F-1.8E	180	240	1.25	38

Southern Pine Advantages

- Dependable structural species for engineered and framing applications
- High density provides excellent fastener strength
- Cost-competitive choice
- Accepted by building codes
- Readily available from a local building material supplier
- Easy to handle, cut, and install
- Kiln-dried to enhance in-place performance and dimensional stability
- Easily treated with preservatives for high-moisture applications
- Lends warmth and unmatched beauty to any project
- Renewable and sustainable building material

Assumptions for Table Development

The *Size Selection* and *Allowable Load Tables* in this brochure have been developed for Southern Pine lumber and glued laminated timber. Southern Pine lumber sizes are provided with the number of pieces (plies) required shown in parentheses (e.g. (3) 2x10s). For the *Size Selection Tables*, Southern Pine glued laminated timber sizes are only provided in the header tables (Tables 1-12) when (3) 2x12s no longer meet design parameters, and in the beam tables (Tables 13-20) when (4) 2x12s no longer meet design parameters.

General Requirements

These tables only apply to Southern Pine lumber and glued laminated timber used under ordinary ranges of temperature and dry service conditions. The moisture content in use must be a maximum of 19% for lumber, and less than 16% for glued laminated timber.

The quality of wood products and fasteners, and the design of load-supporting members and connections, must conform to the *National Design Specification (NDS)*. All structural members must be framed, anchored, tied, and braced to achieve the required strength and rigidity. Adequate bracing and bridging to resist wind and other lateral forces must be provided.

Loading Conditions

Assumed loading conditions are clearly stated in the heading for each *Size Selection Table*. The range of loads provided accommodates the most common design loads used in the United States, but only gravity loads (i.e. live loads, ground snow loads and dead loads) were considered. Wind and seismic analysis are outside the scope of this publication. Roof live load reductions have not been taken in developing these tables.

The headers and beams in the snow load *Size Selection Tables* (Tables 1-4, 7-10 and 15-18) have been sized using the Design Roof Snow Load shown in the subheading for each table. The Design Roof Snow Load has been derived by reducing the Ground Snow Load listed in each table heading in accordance with

the provisions of Section 7.3 in *ASCE 7-10, Minimum Design Loads for Buildings and Other Structures*. This reduction results in an equivalent balanced Design Roof Snow Load of 0.70 times the Ground Snow Load, with a required minimum of 20 psf (pounds per square foot), when using the following factors:

- Exposure Factor, $C_e = 1.0$
- Thermal Factor, $C_t = 1.0$
- Importance Factor, $I_s = 1.0$

These tables do not consider unbalanced snow loads, drifting or rain-on-snow surcharges that may be required by the building code.

Glued Laminated Timber

In general, glued laminated timber headers and beams are stock items that can be purchased from a local building material supplier. Glued laminated timber is available in a variety of standard widths and depths, strength combinations, unbalanced or balanced beam layouts, cambered or non-cambered beams, four different appearance grades, and stock or custom members.

Common glued laminated timber combinations use an unbalanced layout of laminating lumber grades. This means there is a distinct top and bottom to the glued laminated header or beam. All unbalanced glued laminated timber stock beams are required to have a “TOP” mark, and must only be used with the “TOP” mark facing up. A strength reduction occurs if an unbalanced glued laminated timber is installed upside down, or in a continuous span across supports. An appropriate balanced beam combination, such as 24F-V5, may be used for either simple-span or continuous-span applications.

The majority of stock glued laminated timber is manufactured with camber, but some stock members – especially balanced layout combinations – are manufactured without camber.

For more information about glued laminated timber, contact APA – The Engineered Wood Association at www.apawood.org, or West Coast Lumber Inspection Bureau at www.wclib.org.

Grades and Sizes

The Southern Pine lumber headers and beams have been determined using No.1, No.2 and No.3 grades, and net lumber dimensions (actual sizes), provided by the *American Softwood Lumber Standard PS 20* as follows:

Nominal Size (in.)	Actual Size (in.)
2 x 6	1-1/2 x 5-1/2
2 x 8	1-1/2 x 7-1/4
2 x 10	1-1/2 x 9-1/4
2 x 12	1-1/2 x 11-1/4

The Southern Pine glued laminated timber headers and beams in the *Size Selection Tables* are based on a 24F-1.7E stress class (e.g. 24F-V4 combination), and actual widths of 3-1/2" and 5-1/2"; these widths are typical for a Framing Appearance Grade used in applications where appearance is not critical. The depths of the glued laminated timber headers and beams included in the *Size Selection Tables* are compatible with lumber and I-joist depths.

Because there are other common glued laminated timber strength combinations, widths and depths available in the marketplace, there are three sets of *Allowable Load Tables* included in this publication. The first set (Tables 24, 30 and 36) is based on the same 24F-1.7E stress class, widths and depths included in the *Size Selection Tables*. The second set (Tables 25, 31 and 37) is also based on a 24F-1.7E stress class, but with actual widths of 3-1/8" and 5-1/8" and depths based on actual 1-3/8"-thick laminations. The third set (Tables 26, 32 and 38) is based on a 24F-1.8E stress class (e.g. 24F-V3 combination), actual widths of 3-1/8" and 5-1/8", and depths based on actual 1-3/8"-thick laminations.

Spans

The headers and beams provided in these tables have been computed using Allowable Stress Design and standard engineering design equations for simple span beams with uniformly distributed gravity loads. Uplift loads caused by wind have not been considered, nor have concentrated loads.

Values in these tables have been limited to the minimum number calculated for the following four design parameters:

- Bending (flexure)
- Deflection
- Compression perpendicular-to-grain
- Shear parallel-to-grain (horizontal shear)

Reference Design Values

The following table lists reference design values in pounds per square inch (psi) for Southern Pine glued laminated timber and lumber grades included in this

publication. The glued laminated timber values are from *ANSI 117* and *APA EWS Y117*. The Southern Pine lumber values are new design values effective June 1, 2013 from the *SPIB Grading Rules*.

Southern Pine Glued Laminated Timber and Lumber Reference Design Values						
Property	Glulam 24F-1.7E	Glulam 24F-1.8E	Lumber Size	No.1	No.2	No.3
F_b	2400	2400	2 x 6	1350	1000	575
			2 x 8	1250	925	525
			2 x 10	1050	800	475
			2 x 12	1000	750	450
E	1,700,000	1,800,000	All	1,600,000	1,400,000	1,300,000
$F_{c\perp}$	740	740	All	565	565	565
F_v	175/140*	300	All	175	175	175

*Used $F_v = 175$ psi for 3-1/8" and 3-1/2"-wide glulam, and 140 psi for 5-1/8" and 5-1/2"-wide glulam.

Adjustment Factors

Reference design values must be multiplied by all applicable adjustment factors to determine adjusted design values. The adjustment factors used to develop these tables are described below. Note that reference design values have not been adjusted for buckling. To use these tables, therefore, the compression edge of the header or beam must be laterally supported at intervals of 24" or less. In addition, lateral support must be provided at bearing points.

For more complete information on reference design values and adjustment factors, refer to the *NDS*.

Load Duration Factor, C_D – Wood has the property of carrying substantially greater maximum loads for short durations than for long durations of loading. The following load duration factors have been used to adjust the reference design values for bending and shear.

Load Duration	C_D
Ten years (occupancy live load)	1.00
Two months (snow load)	1.15
Seven days (construction load)	1.25

Repetitive Member Factor, C_R – The repetitive member factor applies to three or more like bending members in contact and properly connected together for load sharing.

Volume Effect Factor, C_V – The volume effect factor equation for Southern Pine glued laminated timber bending members is:

$$C_V = (5.125/b)^{1/20}(12/d)^{1/20}(21/L)^{1/20} \leq 1.0, \text{ where:}$$

b = width of bending member in inches

d = depth of bending member in inches

L = length of bending member between points of zero moment in feet

Bending

Reference design values for bending have been adjusted with the load duration factor shown for each table. For the three- and four-ply lumber members, reference design values for bending have been multiplied by the repetitive member factor, $C_r = 1.15$. For glued laminated timber, reference design values for bending have been multiplied by the volume effect factor, C_V .

Deflection

Deflection may be the controlling factor in determining the member size required when appearance or rigidity is important. Deflection limits are expressed as a fraction of the span length (ℓ) in inches. Building codes have traditionally required certain deflection limits for floor and roof members, but designers must also evaluate other deflection criteria, such as long-term deflection under sustained loads (including creep) and serviceability issues (including vibration). Some structural members, such as headers for wide garage doors, may require more stringent deflection limits. The following deflection limits have been used in the development of the tables in this publication:

Tables	Total Load	Live Load
1-6: Headers	$\ell/180$	$\ell/240$
7-12: Headers	$\ell/240$	$\ell/360$
13-14: Floor Beams	$\ell/240$	$\ell/360$
15-20: Roof Beams	$\ell/180$	$\ell/240$
21-26: Allowable Floor Loads	$\ell/240$	$\ell/360$
27-38: Allowable Roof Loads	$\ell/180$	$\ell/240$

The *Allowable Load Tables* (Tables 21-38) may be used to calculate allowable live loads based on different deflection limits. For example, to determine

allowable live loads for a deflection limit of $\ell/360$ in the *Allowable Roof Load Tables* (Tables 27-38), multiply the tabulated live-load (LL) values by the ratio of $240/360 = 0.67$. The result must not exceed the corresponding total-load (TL) value for the same clear opening and product.

Compression Perpendicular-to-Grain

The required bearing lengths for headers and beams in both the *Size Selection* and *Allowable Load Tables* have been based on the compression perpendicular-to-grain design value for the product indicated. The *Size Selection Tables* require a minimum 3.0" bearing length, with the products marked with an asterisk (*) requiring a 4.5" bearing length.

For the *Allowable Load Tables*, the required bearing lengths have been used to determine the design span, which is defined as the distance from inside face to inside face of supports (i.e. the clear opening) plus one-half the required bearing length at each end. The required bearing lengths have been converted into the minimum number of 1.5"-wide members needed to support the header or beam. Nominal 2"-thick vertical lumber trimmers or shoulder studs are most often used for this application. The 1.5" trimmers are assumed to provide full support across the width of the header or beam. Column buckling has not been considered and may need to be checked depending on the grade, species and height of the trimmers. If bearing occurs on a wall plate, check for compression perpendicular-to-grain for the species and grade of that plate.

Shear Parallel-to-Grain

In accordance with *NDS* provisions, loads within a distance from supports equal to the depth of the members have been ignored when calculating the design shear force.



Identification

The tables in this brochure apply to properly identified material. Lumber must be identified by the grade mark of an agency certified by the Board of Review of the American Lumber Standard Committee, and manufactured in accordance with *Product Standard PS 20* published by the U.S. Department of Commerce. A certified grade mark on Southern Pine dimension lumber indicates that the lumber has been properly seasoned by the manufacturer, and that it meets the

structural and appearance requirements established for the grade.

Glued laminated timber must be identified with a quality mark or trademark indicating conformance with *ANSI A190.1, American National Standard for Wood Products – Structural Glued Laminated Timber*. These marks indicate the manufacturer is committed to a rigorous program of quality testing and product verification.

Typical Lumber Grade Marks:

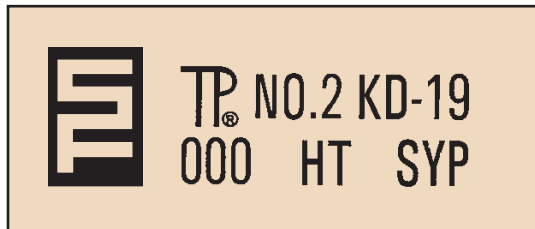

Typical Glued Laminated Timber Marks:

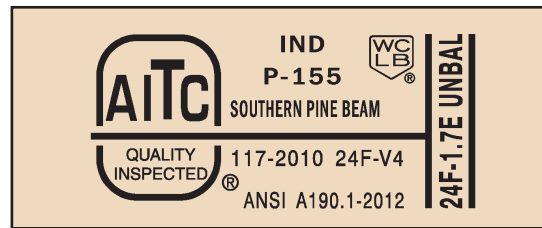
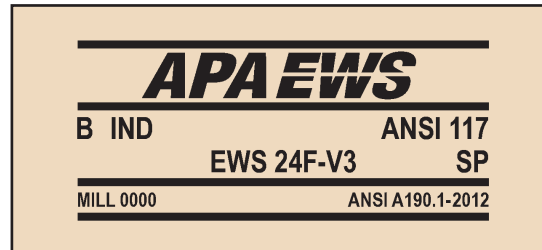

Fabricating Multiple-Member Headers and Beams

Headers and beams can be built-up with multiple pieces (plies) of nominal 2"-thick lumber nailed together with the wide faces positioned vertically. According to AWC's *Details for Conventional Wood Frame Construction*, multiple plies should be nailed together with two rows of 20d nails – one row near the top edge of the header or beam, and the other near the bottom edge. Nails in each row are spaced 32 inches apart.

End joints of the nailed lumber should occur over the supporting column or pier. Beams and girders that are not continuous should be tied together across supports. This is most often accomplished by nailing a steel strap or tie to both beams, but other methods are acceptable.

A nominal 1/2" (15/32") wood structural panel filler is often used to fill out two plies of a nominal 2"-thick lumber header to match a 3-1/2" wall width.

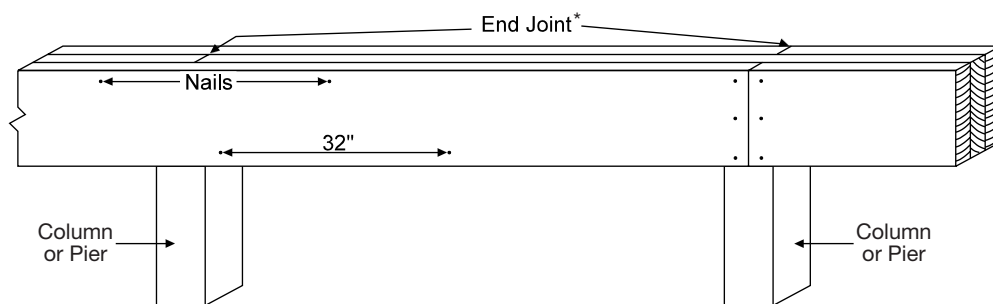

*Beam continuity is maintained by staggering end joints of adjacent plies.

Typical Header and Beam Connections

Beam to Masonry or Concrete Wall

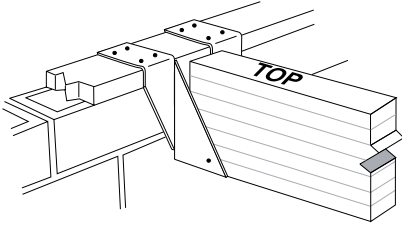

Note: Maintain 1/2" air space around the end of the wood beam.

Beam to Column

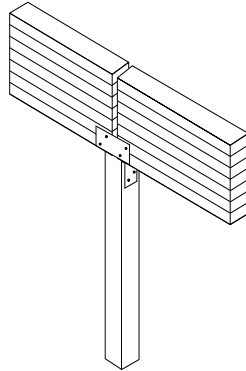

Beam to Beam

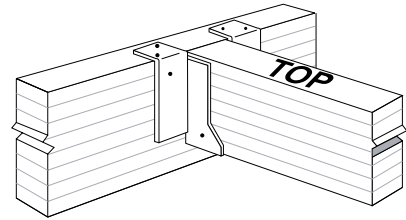

Header to Frame

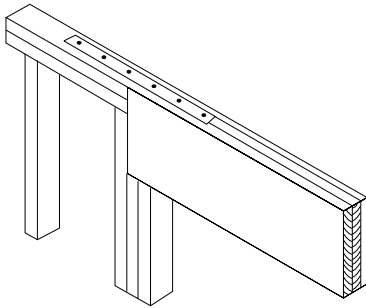

Braced Wall Detail for Garage Door Header

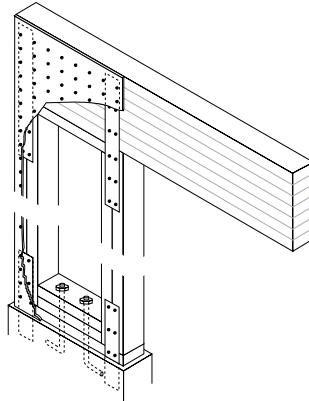

Note: Building codes may require detailed bracing for wall sections less than 4' in length adjacent to garage door openings.

Header to Header

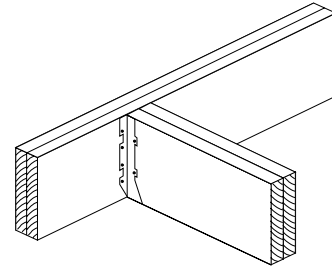

Beam to Concrete Wall Pocket

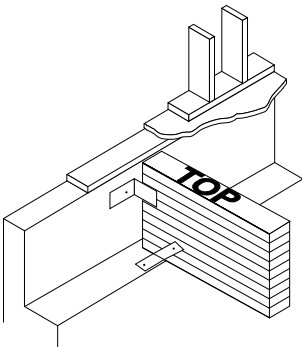

Note: Maintain 1/2" air space between the end of the wood beam and the concrete wall. A moisture barrier is required between the bottom of the beam and the concrete wall.

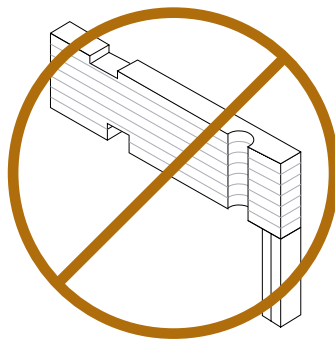

Caution: Do not cut, drill or notch headers or beams.

Beam Bearing on Trimmers Inside Wall Framing

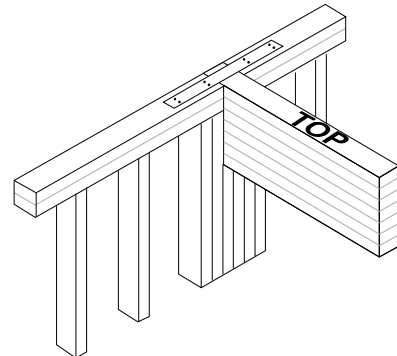

Note: Follow code requirements for nailing schedules, allowable loads, proper straps and proper bearing conditions. Details shown apply to both lumber or glued laminated timber headers and beams.

SOUTHERN PINE SIZE SELECTION TABLES



Requirements for Use of Size Selection Tables

1. These tables are for gravity loads only. Consult a registered design professional for wind and seismic load analysis and design.
2. All tables are based on uniformly distributed loads only. Other loads, such as concentrated or unbalanced snow loads, have not been considered and must be analyzed separately.
3. These tables are only applicable to members used under dry-service conditions where the moisture content in use is a maximum of 19% for lumber and less than 16% for glued laminated timber.
4. The compression edge of the header or beam must be laterally supported at intervals of 24" or less. In addition, lateral support must be provided at bearing points.
5. Design loads used to select a header or beam must be equal to or greater than the actual applied loads.
6. Multiple-member headers and beams must be properly connected together. See page 5 for connection guidelines.
7. These tables assume unbalanced glued laminated timber combinations used in simple-span applications. Balanced beam combinations with equal or greater design values may be substituted and used in either simple-span or continuous-span applications.
8. These tables are only applicable to members used under ordinary ranges of temperature and occasionally heated in use up to 150° F.

Key

Southern Pine lumber sizes for No.1, No.2 and No.3 grades are shown in regular type with the required number of plies in parentheses. Southern Pine glued laminated timber sizes for a 24F-1.7E (V4) stress class are provided in italics when (3) 2x12s no longer meet design parameters. A 3.0" bearing length is assumed. For other bearing lengths, use the appropriate *Allowable Roof Load Table* (Tables 27-38).

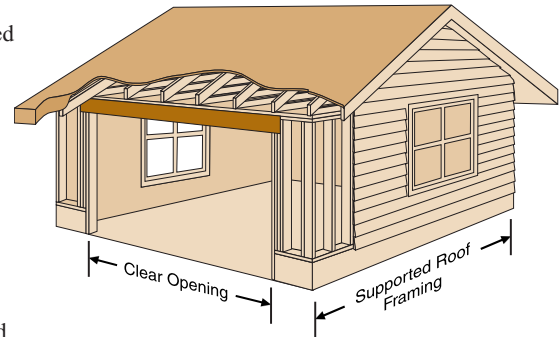

Header size is based on the load transferred from 1/2 the span of the supported roof framing, plus a 24" overhang.

Steps for Using Tables 1-6:

1. Select the table with loading conditions and load duration factor satisfying the intended application.
2. Find the span of supported roof framing (i.e. span of trusses or rafters that frame into the header) that equals or exceeds the intended application.
3. Find the clear opening that equals or exceeds the intended application.
4. Select product size for the appropriate grade, clear opening and span of supported roof framing.

Table 1 – 30 psf Ground Snow Load **, 10 psf Dead Load, 1.15 Load Duration Factor								
**Equivalent to a 21 psf Design Roof Snow Load								
Grade	Clear Opening	Span of Supported Roof Framing						
		16'	20'	24'	28'	32'	36'	40'
No. 1	4'	(1) 2 x 6	(1) 2 x 6	(1) 2 x 8	(1) 2 x 8	(1) 2 x 8	(1) 2 x 8	(1) 2 x 8
	6'	(1) 2 x 8	(1) 2 x 10	(1) 2 x 10	(1) 2 x 10	(1) 2 x 12	(1) 2 x 12	(2) 2 x 10s
	8'	(1) 2 x 12	(2) 2 x 10s	(2) 2 x 10s	(2) 2 x 10s	(2) 2 x 12s	(2) 2 x 12s	(2) 2 x 12s
	9'	(2) 2 x 10s	(2) 2 x 10s	(2) 2 x 12s	(2) 2 x 12s	(2) 2 x 12s	(3) 2 x 10s	(3) 2 x 10s
	10'	(2) 2 x 10s	(2) 2 x 12s	(2) 2 x 12s	(3) 2 x 10s	(3) 2 x 10s	(3) 2 x 12s	(3) 2 x 12s
	12'	(2) 2 x 12s	(3) 2 x 10s	(3) 2 x 12s	(3) 2 x 12s	3-1/2 x 9-1/4	3-1/2 x 9-1/2	3-1/2 x 11-1/4
	16'	(3) 2 x 12s	3-1/2 x 11-1/4	3-1/2 x 11-1/4	3-1/2 x 11-7/8	3-1/2 x 11-7/8	3-1/2 x 14	3-1/2 x 14
	18'	3-1/2 x 11-1/4	3-1/2 x 11-7/8	3-1/2 x 14	3-1/2 x 14	3-1/2 x 14	3-1/2 x 14	3-1/2 x 16
No. 2	4'	(1) 2 x 6	(1) 2 x 8	(1) 2 x 8	(1) 2 x 8	(1) 2 x 10	(1) 2 x 10	(1) 2 x 10
	6'	(1) 2 x 10	(1) 2 x 12	(1) 2 x 12	(2) 2 x 10s	(2) 2 x 10s	(2) 2 x 10s	(2) 2 x 12s
	8'	(2) 2 x 10s	(2) 2 x 10s	(2) 2 x 12s	(2) 2 x 12s	(3) 2 x 10s	(3) 2 x 10s	(3) 2 x 12s
	9'	(2) 2 x 12s	(2) 2 x 12s	(3) 2 x 10s	(3) 2 x 10s	(3) 2 x 12s	(3) 2 x 12s	(3) 2 x 12s
	10'	(2) 2 x 12s	(3) 2 x 10s	(3) 2 x 12s	(3) 2 x 12s	(3) 2 x 12s	3-1/2 x 9-1/4	3-1/2 x 9-1/4
	12'	(3) 2 x 12s	(3) 2 x 12s	3-1/2 x 9-1/4	3-1/2 x 9-1/4	3-1/2 x 9-1/4	3-1/2 x 9-1/2	3-1/2 x 11-1/4
	16'	3-1/2 x 11-1/4	3-1/2 x 11-1/4	3-1/2 x 11-1/4	3-1/2 x 11-7/8	3-1/2 x 11-7/8	3-1/2 x 14	3-1/2 x 14
	18'	3-1/2 x 11-1/4	3-1/2 x 11-7/8	3-1/2 x 14	3-1/2 x 14	3-1/2 x 14	3-1/2 x 14	3-1/2 x 16
No. 3	4'	(1) 2 x 10	(1) 2 x 10	(1) 2 x 12	(1) 2 x 12	(1) 2 x 12	(2) 2 x 10s	(2) 2 x 10s
	6'	(2) 2 x 10s	(2) 2 x 10s	(2) 2 x 12s	(2) 2 x 12s	(2) 2 x 12s	(3) 2 x 10s	(3) 2 x 10s
	8'	(2) 2 x 12s	(3) 2 x 10s	(3) 2 x 12s	(3) 2 x 12s	3-1/2 x 9-1/4	3-1/2 x 9-1/4	3-1/2 x 9-1/4
	9'	(3) 2 x 10s	(3) 2 x 12s	(3) 2 x 12s	3-1/2 x 9-1/4	3-1/2 x 9-1/4	3-1/2 x 9-1/4	3-1/2 x 9-1/4
	10'	(3) 2 x 12s	3-1/2 x 9-1/4	3-1/2 x 9-1/4	3-1/2 x 9-1/4	3-1/2 x 9-1/4	3-1/2 x 9-1/4	3-1/2 x 9-1/4
	12'	3-1/2 x 9-1/4	3-1/2 x 9-1/4	3-1/2 x 9-1/4	3-1/2 x 9-1/4	3-1/2 x 9-1/4	3-1/2 x 9-1/2	3-1/2 x 11-1/4
	16'	3-1/2 x 11-1/4	3-1/2 x 11-1/4	3-1/2 x 11-1/4	3-1/2 x 11-7/8	3-1/2 x 11-7/8	3-1/2 x 14	3-1/2 x 14
	18'	3-1/2 x 11-1/4	3-1/2 x 11-7/8	3-1/2 x 14	3-1/2 x 14	3-1/2 x 14	3-1/2 x 14	3-1/2 x 16

(See Requirements for Use on page 7, Key and Notes on this page, and Example on page 11)

Notes for Tables 1 - 6: Window, Door & Garage Door Headers – Supporting Roof Loads Only

- Tables 1-6 apply to headers carrying only uniformly distributed roof loads. For headers supporting uniformly distributed floor, roof and exterior wall loads, use the appropriate table for *Window, Door & Garage Door Headers – Supporting Roof, Wall & Floor Loads* (Tables 7-12).
- See *Assumptions for Table Development* beginning on page 2 for details on design assumptions made to generate these tables.
- Header size is based on the load transferred from 1/2 the span of the supported roof framing, plus a 24" overhang.
- Deflection is limited to $\ell/180$ for total load and $\ell/240$ for live load.
- Design Roof Snow Loads have been derived by reducing Ground Snow Loads in accordance with *ASCE 7-10*, Section 7.3. This results in an equivalent balanced Design Roof Snow Load of 0.70 times the Ground Snow Load, with a required minimum of 20 psf (pounds per square foot). Unbalanced snow loads, drifting or rain-on-snow surcharges have not been considered. Roof live load reductions have not been taken.
- For loading conditions other than those provided in Tables 1-6, use another table in this section with higher loading conditions than required, or use the *Allowable Roof Load Table* with the corresponding load duration factor (Tables 27-38). For clear openings other than those provided, use the next larger clear opening shown, or use the appropriate *Allowable Roof Load Table*.
- All (1) ply lumber headers may be replaced with (2) 2x8s of the same or better grade.
- Tabulated glued laminated timber sizes may be replaced with other glued laminated timber sizes and/or stress classes with equal or greater load capacity (plf); refer to the appropriate *Allowable Roof Load Tables* (Tables 30-32 or 36-38) to determine acceptable options.

Table 2 – 40 psf Ground Snow Load **, 10 psf Dead Load, 1.15 Load Duration Factor

**Equivalent to a 28 psf Design Roof Snow Load

Grade	Clear Opening	Span of Supported Roof Framing						
		16'	20'	24'	28'	32'	36'	40'
No. 1	4'	(1) 2 x 6	(1) 2 x 8	(1) 2 x 8	(1) 2 x 8	(1) 2 x 8	(1) 2 x 10	(1) 2 x 10
	6'	(1) 2 x 10	(1) 2 x 12	(1) 2 x 12	(1) 2 x 12	(2) 2 x 10s	(2) 2 x 10s	(2) 2 x 10s
	8'	(2) 2 x 10s	(2) 2 x 10s	(2) 2 x 12s	(2) 2 x 12s	(2) 2 x 12s	(3) 2 x 10s	(3) 2 x 10s
	9'	(2) 2 x 10s	(2) 2 x 12s	(2) 2 x 12s	(3) 2 x 10s	(3) 2 x 10s	(3) 2 x 12s	(3) 2 x 12s
	10'	(2) 2 x 12s	(2) 2 x 12s	(3) 2 x 10s	(3) 2 x 12s	(3) 2 x 12s	(3) 2 x 12s	3-1/2 x 9-1/4
	12'	(3) 2 x 10s	(3) 2 x 12s	(3) 2 x 12s	3-1/2 x 9-1/4	3-1/2 x 11-1/4	3-1/2 x 11-1/4	3-1/2 x 11-1/4
	16'	3-1/2 x 11-1/4	3-1/2 x 11-1/4	3-1/2 x 11-7/8	3-1/2 x 14	3-1/2 x 14	3-1/2 x 14	3-1/2 x 16
	18'	3-1/2 x 11-7/8	3-1/2 x 14	3-1/2 x 14	3-1/2 x 14	3-1/2 x 16	3-1/2 x 16	3-1/2 x 18
No. 2	4'	(1) 2 x 8	(1) 2 x 8	(1) 2 x 10	(1) 2 x 10	(1) 2 x 10	(1) 2 x 12	(1) 2 x 12
	6'	(1) 2 x 12	(1) 2 x 12	(2) 2 x 10s	(2) 2 x 10s	(2) 2 x 12s	(2) 2 x 12s	(2) 2 x 12s
	8'	(2) 2 x 10s	(2) 2 x 12s	(2) 2 x 12s	(3) 2 x 10s	(3) 2 x 12s	(3) 2 x 12s	(3) 2 x 12s
	9'	(2) 2 x 12s	(3) 2 x 10s	(3) 2 x 12s	(3) 2 x 12s	(3) 2 x 12s	3-1/2 x 9-1/4	3-1/2 x 9-1/4
	10'	(3) 2 x 10s	(3) 2 x 12s	(3) 2 x 12s	3-1/2 x 9-1/4	3-1/2 x 9-1/4	3-1/2 x 9-1/4	3-1/2 x 9-1/4
	12'	(3) 2 x 12s	3-1/2 x 9-1/4	3-1/2 x 9-1/4	3-1/2 x 9-1/4	3-1/2 x 11-1/4	3-1/2 x 11-1/4	3-1/2 x 11-1/4
	16'	3-1/2 x 11-1/4	3-1/2 x 11-1/4	3-1/2 x 11-7/8	3-1/2 x 14	3-1/2 x 14	3-1/2 x 14	3-1/2 x 16
	18'	3-1/2 x 11-7/8	3-1/2 x 14	3-1/2 x 14	3-1/2 x 14	3-1/2 x 16	3-1/2 x 16	3-1/2 x 18
No. 3	4'	(1) 2 x 10	(1) 2 x 12	(1) 2 x 12	(2) 2 x 10s	(2) 2 x 10s	(2) 2 x 10s	(2) 2 x 10s
	6'	(2) 2 x 10s	(2) 2 x 12s	(2) 2 x 12s	(3) 2 x 10s	(3) 2 x 10s	(3) 2 x 12s	(3) 2 x 12s
	8'	(3) 2 x 10s	(3) 2 x 12s	(3) 2 x 12s	3-1/2 x 9-1/4	3-1/2 x 9-1/4	3-1/2 x 9-1/4	3-1/2 x 9-1/4
	9'	(3) 2 x 12s	3-1/2 x 9-1/4	3-1/2 x 9-1/4	3-1/2 x 9-1/4	3-1/2 x 9-1/4	3-1/2 x 9-1/4	3-1/2 x 9-1/4
	10'	3-1/2 x 9-1/4	3-1/2 x 9-1/4	3-1/2 x 9-1/4	3-1/2 x 9-1/4	3-1/2 x 9-1/4	3-1/2 x 9-1/4	3-1/2 x 9-1/4
	12'	3-1/2 x 9-1/4	3-1/2 x 9-1/4	3-1/2 x 9-1/4	3-1/2 x 9-1/4	3-1/2 x 11-1/4	3-1/2 x 11-1/4	3-1/2 x 11-1/4
	16'	3-1/2 x 11-1/4	3-1/2 x 11-1/4	3-1/2 x 11-7/8	3-1/2 x 14	3-1/2 x 14	3-1/2 x 14	3-1/2 x 16
	18'	3-1/2 x 11-7/8	3-1/2 x 14	3-1/2 x 14	3-1/2 x 14	3-1/2 x 16	3-1/2 x 16	3-1/2 x 18

Table 3 – 50 psf Ground Snow Load **, 10 psf Dead Load, 1.15 Load Duration Factor

**Equivalent to a 35 psf Design Roof Snow Load

Grade	Clear Opening	Span of Supported Roof Framing						
		16'	20'	24'	28'	32'	36'	40'
No. 1	4'	(1) 2 x 8	(1) 2 x 8	(1) 2 x 8	(1) 2 x 10	(1) 2 x 10	(1) 2 x 10	(1) 2 x 12
	6'	(1) 2 x 12	(1) 2 x 12	(2) 2 x 8s	(2) 2 x 10s	(2) 2 x 10s	(2) 2 x 12s	(2) 2 x 12s
	8'	(2) 2 x 10s	(2) 2 x 12s	(2) 2 x 12s	(3) 2 x 10s	(3) 2 x 10s	(3) 2 x 12s	(3) 2 x 12s
	9'	(2) 2 x 12s	(2) 2 x 12s	(3) 2 x 10s	(3) 2 x 12s	(3) 2 x 12s	(3) 2 x 12s	3-1/2 x 9-1/4
	10'	(2) 2 x 12s	(3) 2 x 10s	(3) 2 x 12s	(3) 2 x 12s	3-1/2 x 9-1/4	3-1/2 x 9-1/2	3-1/2 x 11-1/4
	12'	(3) 2 x 12s	(3) 2 x 12s	3-1/2 x 9-1/2	3-1/2 x 11-1/4	3-1/2 x 11-1/4	3-1/2 x 11-1/4	3-1/2 x 11-7/8
	16'	3-1/2 x 11-1/4	3-1/2 x 11-7/8	3-1/2 x 14	3-1/2 x 14	3-1/2 x 16	3-1/2 x 16	5-1/2 x 14
	18'	3-1/2 x 14	3-1/2 x 14	3-1/2 x 14	3-1/2 x 16	3-1/2 x 16	5-1/2 x 14	5-1/2 x 16
No. 2	4'	(1) 2 x 8	(1) 2 x 10	(1) 2 x 10	(1) 2 x 10	(1) 2 x 12	(1) 2 x 12	(1) 2 x 12
	6'	(1) 2 x 12	(2) 2 x 10s	(2) 2 x 10s	(2) 2 x 12s	(2) 2 x 12s	(2) 2 x 12s	(3) 2 x 10s
	8'	(2) 2 x 12s	(3) 2 x 10s	(3) 2 x 10s	(3) 2 x 12s	(3) 2 x 12s	(3) 2 x 12s	3-1/2 x 9-1/4
	9'	(3) 2 x 10s	(3) 2 x 12s	(3) 2 x 12s	(3) 2 x 12s	3-1/2 x 9-1/4	3-1/2 x 9-1/4	3-1/2 x 9-1/4
	10'	(3) 2 x 12s	(3) 2 x 12s	3-1/2 x 9-1/4	3-1/2 x 9-1/4	3-1/2 x 9-1/4	3-1/2 x 9-1/2	3-1/2 x 11-1/4
	12'	3-1/2 x 9-1/4	3-1/2 x 9-1/4	3-1/2 x 9-1/2	3-1/2 x 11-1/4	3-1/2 x 11-1/4	3-1/2 x 11-1/4	3-1/2 x 11-7/8
	16'	3-1/2 x 11-1/4	3-1/2 x 11-7/8	3-1/2 x 14	3-1/2 x 14	3-1/2 x 16	3-1/2 x 16	5-1/2 x 14
	18'	3-1/2 x 14	3-1/2 x 14	3-1/2 x 14	3-1/2 x 16	3-1/2 x 16	5-1/2 x 14	5-1/2 x 16
No. 3	4'	(1) 2 x 12	(1) 2 x 12	(2) 2 x 10s	(2) 2 x 10s	(2) 2 x 10s	(2) 2 x 12s	(2) 2 x 12s
	6'	(2) 2 x 12s	(2) 2 x 12s	(3) 2 x 10s	(3) 2 x 12s	(3) 2 x 12s	(3) 2 x 12s	3-1/2 x 9-1/4
	8'	(3) 2 x 12s	(3) 2 x 12s	3-1/2 x 9-1/4	3-1/2 x 9-1/4	3-1/2 x 9-1/4	3-1/2 x 9-1/4	3-1/2 x 9-1/4
	9'	3-1/2 x 9-1/4	3-1/2 x 9-1/4	3-1/2 x 9-1/4	3-1/2 x 9-1/4	3-1/2 x 9-1/4	3-1/2 x 9-1/4	3-1/2 x 9-1/4
	10'	3-1/2 x 9-1/4	3-1/2 x 9-1/4	3-1/2 x 9-1/4	3-1/2 x 9-1/4	3-1/2 x 9-1/4	3-1/2 x 9-1/2	3-1/2 x 11-1/4
	12'	3-1/2 x 9-1/4	3-1/2 x 9-1/4	3-1/2 x 9-1/2	3-1/2 x 11-1/4	3-1/2 x 11-1/4	3-1/2 x 11-1/4	3-1/2 x 11-7/8
	16'	3-1/2 x 11-1/4	3-1/2 x 11-7/8	3-1/2 x 14	3-1/2 x 14	3-1/2 x 16	3-1/2 x 16	5-1/2 x 14
	18'	3-1/2 x 14	3-1/2 x 14	3-1/2 x 14	3-1/2 x 16	3-1/2 x 16	5-1/2 x 14	5-1/2 x 16

(See Requirements for Use on page 7, Key and Notes on page 8, and Example on page 11)

Table 4 – 70 psf Ground Snow Load **, 10 psf Dead Load, 1.15 Load Duration Factor
**Equivalent to a 49 psf Design Roof Snow Load

Grade	Clear Opening	Span of Supported Roof Framing						
		16'	20'	24'	28'	32'	36'	40'
No. 1	4'	(1) 2 x 8	(1) 2 x 10	(1) 2 x 10	(1) 2 x 10	(1) 2 x 12	(1) 2 x 12	(2) 2 x 8s
	6'	(1) 2 x 12	(2) 2 x 10s	(2) 2 x 10s	(2) 2 x 12s	(2) 2 x 12s	(2) 2 x 12s	(3) 2 x 10s
	8'	(2) 2 x 12s	(2) 2 x 12s	(3) 2 x 10s	(3) 2 x 12s	(3) 2 x 12s	(3) 2 x 12s	3-1/2 x 9-1/4
	9'	(3) 2 x 10s	(3) 2 x 12s	(3) 2 x 12s	(3) 2 x 12s	3-1/2 x 9-1/4	3-1/2 x 11-1/4	3-1/2 x 11-1/4
	10'	(3) 2 x 12s	(3) 2 x 12s	3-1/2 x 9-1/4	3-1/2 x 11-1/4	3-1/2 x 11-1/4	3-1/2 x 11-1/4	3-1/2 x 11-7/8
	12'	3-1/2 x 9-1/2	3-1/2 x 11-1/4	3-1/2 x 11-1/4	3-1/2 x 11-7/8	3-1/2 x 14	3-1/2 x 14	5-1/2 x 11-1/4
	16'	3-1/2 x 14	3-1/2 x 14	3-1/2 x 16	3-1/2 x 16	5-1/2 x 14	5-1/2 x 14	5-1/2 x 16
	18'	3-1/2 x 14	3-1/2 x 16	3-1/2 x 18	5-1/2 x 16	5-1/2 x 16	5-1/2 x 16	5-1/2 x 18
No. 2	4'	(1) 2 x 10	(1) 2 x 10	(1) 2 x 12	(1) 2 x 12	(2) 2 x 10s	(2) 2 x 10s	(2) 2 x 10s
	6'	(2) 2 x 10s	(2) 2 x 12s	(2) 2 x 12s	(3) 2 x 10s	(3) 2 x 10s	(3) 2 x 12s	(3) 2 x 12s
	8'	(3) 2 x 10s	(3) 2 x 12s	(3) 2 x 12s	3-1/2 x 9-1/4	3-1/2 x 9-1/4	3-1/2 x 9-1/4	3-1/2 x 9-1/4
	9'	(3) 2 x 12s	(3) 2 x 12s	3-1/2 x 9-1/4	3-1/2 x 9-1/4	3-1/2 x 9-1/4	3-1/2 x 11-1/4	3-1/2 x 11-1/4
	10'	(3) 2 x 12s	3-1/2 x 9-1/4	3-1/2 x 9-1/4	3-1/2 x 11-1/4	3-1/2 x 11-1/4	3-1/2 x 11-1/4	3-1/2 x 11-7/8
	12'	3-1/2 x 9-1/2	3-1/2 x 11-1/4	3-1/2 x 11-1/4	3-1/2 x 11-7/8	3-1/2 x 14	3-1/2 x 14	5-1/2 x 11-1/4
	16'	3-1/2 x 14	3-1/2 x 14	3-1/2 x 16	3-1/2 x 16	5-1/2 x 14	5-1/2 x 14	5-1/2 x 16
	18'	3-1/2 x 14	3-1/2 x 16	3-1/2 x 18	5-1/2 x 16	5-1/2 x 16	5-1/2 x 16	5-1/2 x 18
No. 3	4'	(1) 2 x 12	(2) 2 x 10s	(2) 2 x 10s	(2) 2 x 12s	(2) 2 x 12s	(2) 2 x 12s	(3) 2 x 10s
	6'	(3) 2 x 10s	(3) 2 x 12s	(3) 2 x 12s	(3) 2 x 12s	3-1/2 x 9-1/4	3-1/2 x 9-1/4	3-1/2 x 9-1/4
	8'	3-1/2 x 9-1/4	3-1/2 x 9-1/4	3-1/2 x 9-1/4	3-1/2 x 9-1/4	3-1/2 x 9-1/4	3-1/2 x 9-1/4	3-1/2 x 9-1/4
	9'	3-1/2 x 9-1/4	3-1/2 x 9-1/4	3-1/2 x 9-1/4	3-1/2 x 9-1/4	3-1/2 x 9-1/4	3-1/2 x 11-1/4	3-1/2 x 11-1/4
	10'	3-1/2 x 9-1/4	3-1/2 x 9-1/4	3-1/2 x 9-1/4	3-1/2 x 11-1/4	3-1/2 x 11-1/4	3-1/2 x 11-1/4	3-1/2 x 11-7/8
	12'	3-1/2 x 9-1/2	3-1/2 x 11-1/4	3-1/2 x 11-1/4	3-1/2 x 11-7/8	3-1/2 x 14	3-1/2 x 14	5-1/2 x 11-1/4
	16'	3-1/2 x 14	3-1/2 x 14	3-1/2 x 16	3-1/2 x 16	5-1/2 x 14	5-1/2 x 14	5-1/2 x 16
	18'	3-1/2 x 14	3-1/2 x 16	3-1/2 x 18	5-1/2 x 16	5-1/2 x 16	5-1/2 x 16	5-1/2 x 18

Table 5 – 20 psf Live Load, 10 psf Dead Load, 1.25 Load Duration Factor

Grade	Clear Opening	Span of Supported Roof Framing						
		16'	20'	24'	28'	32'	36'	40'
No. 1	4'	(1) 2 x 6	(1) 2 x 6	(1) 2 x 6	(1) 2 x 8	(1) 2 x 8	(1) 2 x 8	(1) 2 x 8
	6'	(1) 2 x 8	(1) 2 x 10	(1) 2 x 10	(1) 2 x 12	(1) 2 x 12	(1) 2 x 12	(1) 2 x 12
	8'	(1) 2 x 12	(1) 2 x 12	(2) 2 x 10s	(2) 2 x 10s	(2) 2 x 10s	(2) 2 x 12s	(2) 2 x 12s
	9'	(1) 2 x 12	(2) 2 x 10s	(2) 2 x 10s	(2) 2 x 12s	(2) 2 x 12s	(2) 2 x 12s	(3) 2 x 10s
	10'	(2) 2 x 10s	(2) 2 x 12s	(2) 2 x 12s	(2) 2 x 12s	(3) 2 x 10s	(3) 2 x 10s	(3) 2 x 12s
	12'	(2) 2 x 12s	(3) 2 x 10s	(3) 2 x 10s	(3) 2 x 12s	(3) 2 x 12s	(3) 2 x 12s	3-1/2 x 9-1/2
	16'	(3) 2 x 12s	3-1/2 x 11-1/4	3-1/2 x 11-1/4	3-1/2 x 11-1/4	3-1/2 x 11-7/8	3-1/2 x 14	3-1/2 x 14
	18'	3-1/2 x 11-1/4	3-1/2 x 11-7/8	3-1/2 x 14	3-1/2 x 14	3-1/2 x 14	3-1/2 x 14	3-1/2 x 14
No. 2	4'	(1) 2 x 6	(1) 2 x 8	(1) 2 x 8	(1) 2 x 8	(1) 2 x 8	(1) 2 x 10	(1) 2 x 10
	6'	(1) 2 x 10	(1) 2 x 10	(1) 2 x 12	(1) 2 x 12	(2) 2 x 10s	(2) 2 x 10s	(2) 2 x 10s
	8'	(2) 2 x 10s	(2) 2 x 10s	(2) 2 x 12s	(2) 2 x 12s	(2) 2 x 12s	(3) 2 x 10s	(3) 2 x 10s
	9'	(2) 2 x 10s	(2) 2 x 12s	(2) 2 x 12s	(3) 2 x 10s	(3) 2 x 10s	(3) 2 x 12s	(3) 2 x 12s
	10'	(2) 2 x 12s	(2) 2 x 12s	(3) 2 x 10s	(3) 2 x 12s	(3) 2 x 12s	(3) 2 x 12s	3-1/2 x 9-1/4
	12'	(3) 2 x 10s	(3) 2 x 12s	(3) 2 x 12s	3-1/2 x 9-1/4	3-1/2 x 9-1/4	3-1/2 x 9-1/4	3-1/2 x 9-1/2
	16'	3-1/2 x 11-1/4	3-1/2 x 11-1/4	3-1/2 x 11-1/4	3-1/2 x 11-1/4	3-1/2 x 11-7/8	3-1/2 x 14	3-1/2 x 14
	18'	3-1/2 x 11-1/4	3-1/2 x 11-7/8	3-1/2 x 14	3-1/2 x 14	3-1/2 x 14	3-1/2 x 14	3-1/2 x 14
No. 3	4'	(1) 2 x 8	(1) 2 x 10	(1) 2 x 10	(1) 2 x 12	(1) 2 x 12	(1) 2 x 12	(2) 2 x 10s
	6'	(1) 2 x 12	(2) 2 x 10s	(2) 2 x 10s	(2) 2 x 12s	(2) 2 x 12s	(2) 2 x 12s	(3) 2 x 10s
	8'	(2) 2 x 12s	(3) 2 x 10s	(3) 2 x 10s	(3) 2 x 12s	(3) 2 x 12s	(3) 2 x 12s	3-1/2 x 9-1/4
	9'	(3) 2 x 10s	(3) 2 x 12s	(3) 2 x 12s	3-1/2 x 9-1/4	3-1/2 x 9-1/4	3-1/2 x 9-1/4	3-1/2 x 9-1/4
	10'	(3) 2 x 12s	(3) 2 x 12s	3-1/2 x 9-1/4	3-1/2 x 9-1/4	3-1/2 x 9-1/4	3-1/2 x 9-1/4	3-1/2 x 9-1/4
	12'	3-1/2 x 9-1/4	3-1/2 x 9-1/4	3-1/2 x 9-1/4	3-1/2 x 9-1/4	3-1/2 x 9-1/4	3-1/2 x 9-1/4	3-1/2 x 9-1/2
	16'	3-1/2 x 11-1/4	3-1/2 x 11-1/4	3-1/2 x 11-1/4	3-1/2 x 11-1/4	3-1/2 x 11-7/8	3-1/2 x 14	3-1/2 x 14
	18'	3-1/2 x 11-1/4	3-1/2 x 11-7/8	3-1/2 x 14	3-1/2 x 14	3-1/2 x 14	3-1/2 x 14	3-1/2 x 14

(See Requirements for Use on page 7, Key and Notes on page 8, and Example on page 11)

Table 6 – 20 psf Live Load, 20 psf Dead Load, 1.25 Load Duration Factor								
Grade	Clear Opening	Span of Supported Roof Framing						
		16'	20'	24'	28'	32'	36'	40'
No. 1	4'	(1) 2 x 6	(1) 2 x 8	(1) 2 x 8	(1) 2 x 8	(1) 2 x 8	(1) 2 x 10	(1) 2 x 10
	6'	(1) 2 x 10	(1) 2 x 12	(1) 2 x 12	(1) 2 x 12	(2) 2 x 10s	(2) 2 x 10s	(2) 2 x 10s
	8'	(2) 2 x 8s	(2) 2 x 10s	(2) 2 x 12s	(2) 2 x 12s	(2) 2 x 12s	(3) 2 x 10s	(3) 2 x 10s
	9'	(2) 2 x 10s	(2) 2 x 12s	(2) 2 x 12s	(3) 2 x 10s	(3) 2 x 10s	(3) 2 x 12s	(3) 2 x 12s
	10'	(2) 2 x 12s	(2) 2 x 12s	(3) 2 x 10s	(3) 2 x 12s	(3) 2 x 12s	(3) 2 x 12s	3-1/2 x 9-1/4
	12'	(3) 2 x 10s	(3) 2 x 12s	(3) 2 x 12s	3-1/2 x 9-1/2	3-1/2 x 11-1/4	3-1/2 x 11-1/4	3-1/2 x 11-1/4
	16'	3-1/2 x 11-1/4	3-1/2 x 11-1/4	3-1/2 x 11-7/8	3-1/2 x 14	3-1/2 x 14	3-1/2 x 14	3-1/2 x 16
	18'	3-1/2 x 11-7/8	3-1/2 x 14	3-1/2 x 14	3-1/2 x 14	3-1/2 x 16	3-1/2 x 16	5-1/2 x 14
No. 2	4'	(1) 2 x 8	(1) 2 x 8	(1) 2 x 8	(1) 2 x 10	(1) 2 x 10	(1) 2 x 12	(1) 2 x 12
	6'	(1) 2 x 12	(1) 2 x 12	(2) 2 x 10s	(2) 2 x 10s	(2) 2 x 10s	(2) 2 x 12s	(2) 2 x 12s
	8'	(2) 2 x 10s	(2) 2 x 12s	(2) 2 x 12s	(3) 2 x 10s	(3) 2 x 10s	(3) 2 x 12s	(3) 2 x 12s
	9'	(2) 2 x 12s	(3) 2 x 10s	(3) 2 x 10s	(3) 2 x 12s	(3) 2 x 12s	3-1/2 x 9-1/4	3-1/2 x 9-1/4
	10'	(3) 2 x 10s	(3) 2 x 12s	(3) 2 x 12s	(3) 2 x 12s	3-1/2 x 9-1/4	3-1/2 x 9-1/4	3-1/2 x 9-1/4
	12'	(3) 2 x 12s	3-1/2 x 9-1/4	3-1/2 x 9-1/4	3-1/2 x 9-1/2	3-1/2 x 11-1/4	3-1/2 x 11-1/4	3-1/2 x 11-1/4
	16'	3-1/2 x 11-1/4	3-1/2 x 11-1/4	3-1/2 x 11-7/8	3-1/2 x 14	3-1/2 x 14	3-1/2 x 14	3-1/2 x 16
	18'	3-1/2 x 11-7/8	3-1/2 x 14	3-1/2 x 14	3-1/2 x 14	3-1/2 x 16	3-1/2 x 16	5-1/2 x 14
No. 3	4'	(1) 2 x 10	(1) 2 x 12	(1) 2 x 12	(1) 2 x 12	(2) 2 x 10s	(2) 2 x 10s	(2) 2 x 10s
	6'	(2) 2 x 10s	(2) 2 x 12s	(2) 2 x 12s	(3) 2 x 10s	(3) 2 x 10s	(3) 2 x 12s	(3) 2 x 12s
	8'	(3) 2 x 10s	(3) 2 x 12s	(3) 2 x 12s	3-1/2 x 9-1/4	3-1/2 x 9-1/4	3-1/2 x 9-1/4	3-1/2 x 9-1/4
	9'	(3) 2 x 12s	3-1/2 x 9-1/4	3-1/2 x 9-1/4	3-1/2 x 9-1/4	3-1/2 x 9-1/4	3-1/2 x 9-1/4	3-1/2 x 9-1/4
	10'	3-1/2 x 9-1/4	3-1/2 x 9-1/4	3-1/2 x 9-1/4	3-1/2 x 9-1/4	3-1/2 x 9-1/4	3-1/2 x 9-1/4	3-1/2 x 9-1/4
	12'	3-1/2 x 9-1/4	3-1/2 x 9-1/4	3-1/2 x 9-1/4	3-1/2 x 9-1/2	3-1/2 x 11-1/4	3-1/2 x 11-1/4	3-1/2 x 11-1/4
	16'	3-1/2 x 11-1/4	3-1/2 x 11-1/4	3-1/2 x 11-7/8	3-1/2 x 14	3-1/2 x 14	3-1/2 x 14	3-1/2 x 16
	18'	3-1/2 x 11-7/8	3-1/2 x 14	3-1/2 x 14	3-1/2 x 14	3-1/2 x 16	3-1/2 x 16	5-1/2 x 14

(See Requirements for Use on page 7, Key and Notes on page 8, and Example on this page)

EXAMPLE: Garage Door Header – Supporting Roof Loads Only
(See Table 5 on page 10)

Live Load = 20 psf

Dead Load = 10 psf

Load Duration Factor = 1.25

Span of Supported Roof Framing = 24'

Clear Opening = 10'

Southern Pine Header Selected: No.1 Southern Pine Lumber - (2) 2x12s or
(from Table 5)

No.2 Southern Pine Lumber - (3) 2x10s or

24F-1.7E (V4) Southern Pine Glulam - 3-1/2" x 9-1/4"

Note: Detailed bracing may be required for wall sections less than 4' in length adjacent to garage door openings. Refer to the *Braced Wall Detail for Garage Door Header* illustration on page 6.

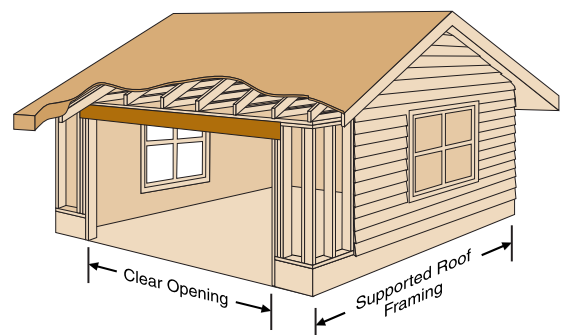

Header size is based on the load transferred from 1/2 the span of the supported roof framing, plus a 24" overhang.

Key

Southern Pine lumber sizes for No.1, No.2 and No.3 grades are shown in regular type with the required number of plies in parentheses. Southern Pine glued laminated timber sizes for a 24F-1.7E (V4) stress class are provided in italics when (3) 2x12s no longer meet design parameters. A 3.0" bearing length is assumed, except for the sizes marked with an asterisk (*) which require a 4.5" bearing length. For other bearing lengths, use the *Allowable Floor Load* tables (Tables 21-26).

Steps for Using Tables 7-12:

1. Select the table with loading conditions and load duration factor satisfying the intended application.
2. Find the span of supported roof and floor framing that equals or exceeds the intended application.
3. Find the clear opening.
4. Select product size for the appropriate grade, clear opening and span of supported roof and floor framing.

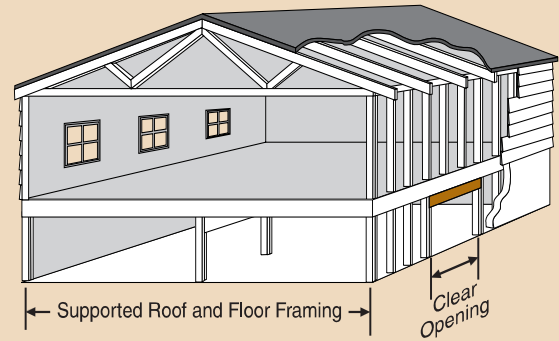

Header size is based on the load transferred from 1/2 the span of the supported roof framing plus a 24" overhang, plus 1/4 the span of the floor framing, plus the wall load.

Table 7 – 30 psf Ground Snow Load **, 10 psf Dead Load, 1.15 Load Duration Factor

****Equivalent to a 21 psf Design Roof Snow Load**

Grade	Clear Opening	Span of Supported Roof & Floor Framing						
		16'	20'	24'	28'	32'	36'	40'
No. 1	4'	(1) 2 x 8	(1) 2 x 10	(1) 2 x 10	(1) 2 x 10	(1) 2 x 12	(1) 2 x 12	(2) 2 x 8s
	6'	(1) 2 x 12	(2) 2 x 10s	(2) 2 x 10s	(2) 2 x 12s	(2) 2 x 12s	(2) 2 x 12s	(3) 2 x 10s
	8'	(2) 2 x 12s	(3) 2 x 10s	(3) 2 x 10s	(3) 2 x 12s	(3) 2 x 12s	(3) 2 x 12s	3-1/2 x 9-1/4
	9'	(3) 2 x 10s	(3) 2 x 12s	(3) 2 x 12s	(3) 2 x 12s	3-1/2 x 9-1/4	3-1/2 x 11-1/4	3-1/2 x 11-1/4
	10'	(3) 2 x 12s	(3) 2 x 12s	3-1/2 x 9-1/2	3-1/2 x 11-1/4	3-1/2 x 11-1/4	3-1/2 x 11-1/4	3-1/2 x 11-1/4
	12'	3-1/2 x 11-1/4	3-1/2 x 11-1/4	3-1/2 x 11-1/4	3-1/2 x 11-7/8	3-1/2 x 14	3-1/2 x 14	5-1/2 x 11-1/4
	16'	3-1/2 x 14	3-1/2 x 16	3-1/2 x 16	3-1/2 x 16	5-1/2 x 14	5-1/2 x 16	5-1/2 x 16
	18'	3-1/2 x 16	3-1/2 x 16	3-1/2 x 18	5-1/2 x 16	5-1/2 x 16	5-1/2 x 18	5-1/2 x 18
No. 2	4'	(1) 2 x 10	(1) 2 x 10	(1) 2 x 12	(1) 2 x 12	(2) 2 x 10s	(2) 2 x 10s	(2) 2 x 10s
	6'	(2) 2 x 10s	(2) 2 x 12s	(2) 2 x 12s	(3) 2 x 10s	(3) 2 x 10s	(3) 2 x 12s	(3) 2 x 12s
	8'	(3) 2 x 10s	(3) 2 x 12s	(3) 2 x 12s	3-1/2 x 9-1/4	3-1/2 x 9-1/4	3-1/2 x 9-1/4	3-1/2 x 9-1/4
	9'	(3) 2 x 12s	(3) 2 x 12s	3-1/2 x 9-1/4	3-1/2 x 9-1/4	3-1/2 x 9-1/4	3-1/2 x 11-1/4	3-1/2 x 11-1/4
	10'	3-1/2 x 9-1/4	3-1/2 x 9-1/4	3-1/2 x 9-1/2	3-1/2 x 11-1/4	3-1/2 x 11-1/4	3-1/2 x 11-1/4	3-1/2 x 11-1/4
	12'	3-1/2 x 11-1/4	3-1/2 x 11-1/4	3-1/2 x 11-1/4	3-1/2 x 11-7/8	3-1/2 x 14	3-1/2 x 14	5-1/2 x 11-1/4
	16'	3-1/2 x 14	3-1/2 x 16	3-1/2 x 16	3-1/2 x 16	5-1/2 x 14	5-1/2 x 16	5-1/2 x 16
	18'	3-1/2 x 16	3-1/2 x 16	3-1/2 x 18	5-1/2 x 16	5-1/2 x 16	5-1/2 x 18	5-1/2 x 18
No. 3	4'	(2) 2 x 10s	(2) 2 x 10s	(2) 2 x 10s	(2) 2 x 12s	(2) 2 x 12s	(2) 2 x 12s	(3) 2 x 10s
	6'	(3) 2 x 10s	(3) 2 x 12s	(3) 2 x 12s	(3) 2 x 12s	3-1/2 x 9-1/4	3-1/2 x 9-1/4	3-1/2 x 9-1/4
	8'	3-1/2 x 9-1/4	3-1/2 x 9-1/4	3-1/2 x 9-1/4	3-1/2 x 9-1/4	3-1/2 x 9-1/4	3-1/2 x 9-1/4	3-1/2 x 9-1/4
	9'	3-1/2 x 9-1/4	3-1/2 x 9-1/4	3-1/2 x 9-1/4	3-1/2 x 9-1/4	3-1/2 x 9-1/4	3-1/2 x 11-1/4	3-1/2 x 11-1/4
	10'	3-1/2 x 9-1/4	3-1/2 x 9-1/4	3-1/2 x 9-1/2	3-1/2 x 11-1/4	3-1/2 x 11-1/4	3-1/2 x 11-1/4	3-1/2 x 11-1/4
	12'	3-1/2 x 11-1/4	3-1/2 x 11-1/4	3-1/2 x 11-1/4	3-1/2 x 11-7/8	3-1/2 x 14	3-1/2 x 14	5-1/2 x 11-1/4
	16'	3-1/2 x 14	3-1/2 x 16	3-1/2 x 16	3-1/2 x 16	5-1/2 x 14	5-1/2 x 16	5-1/2 x 16
	18'	3-1/2 x 16	3-1/2 x 16	3-1/2 x 18	5-1/2 x 16	5-1/2 x 16	5-1/2 x 18	5-1/2 x 18

(See *Requirements for Use* on page 7, *Key* and *Notes* on this page, and *Example* on page 15)

Notes for Tables 7 - 12: Window, Door & Garage Door Headers – Supporting Roof, Wall & Floor Loads

- Tables 7-12 apply to headers carrying only uniformly distributed roof, wall and floor loads.
- See *Assumptions for Table Development* beginning on page 2 for details on design assumptions made to generate these tables.
- Header size is based on the load transferred from 1/2 the span of the supported roof framing plus a 24" overhang, plus 1/4 the span of the floor framing, plus the wall load. The floor load is assumed to be 40 psf live load and 10 psf dead load. The wall load is assumed to be 100 plf (pounds per lineal foot) dead load.
- Deflection is limited to $\ell/240$ for total load and $\ell/360$ for live load.
- Design Roof Snow Loads have been derived by reducing Ground Snow Loads in accordance with *ASCE 7-10*, Section 7.3. This results in an equivalent balanced Design Roof Snow Load of 0.70 times the Ground Snow Load, with a required minimum of 20 psf (pounds per square foot). Unbalanced snow loads, drifting or rain-on-snow surcharges have not been considered. Roof live load reductions have not been taken.
- For loading conditions other than those provided in Tables 7-12, use another table in this section with higher loading conditions than required, or use the *Allowable Floor Load Tables* (Tables 21-26). For clear openings other than those provided, use the next larger clear opening shown, or use the *Allowable Floor Load Tables*.
- All (1) ply lumber headers may be replaced with (2) 2x8s of the same or better grade.
- Tabulated glued laminated timber sizes may be replaced with other glued laminated timber sizes and/or stress classes with equal or greater load capacity (plf); refer to the appropriate *Allowable Floor Load Tables* (Tables 24-26) to determine acceptable options.

Table 8 – 40 psf Ground Snow Load **, 10 psf Dead Load, 1.15 Load Duration Factor								
**Equivalent to a 28 psf Design Roof Snow Load								
Grade	Clear Opening	Span of Supported Roof & Floor Framing						
		16'	20'	24'	28'	32'	36'	40'
No. 1	4'	(1) 2 x 8	(1) 2 x 10	(1) 2 x 10	(1) 2 x 12	(1) 2 x 12	(2) 2 x 8s	(2) 2 x 10s
	6'	(2) 2 x 10s	(2) 2 x 10s	(2) 2 x 12s	(2) 2 x 12s	(2) 2 x 12s	(3) 2 x 10s	(3) 2 x 10s
	8'	(2) 2 x 12s	(3) 2 x 10s	(3) 2 x 12s	(3) 2 x 12s	(3) 2 x 12s	3-1/2 x 9-1/4	3-1/2 x 11-1/4
	9'	(3) 2 x 10s	(3) 2 x 12s	(3) 2 x 12s	3-1/2 x 9-1/4	3-1/2 x 11-1/4	3-1/2 x 11-1/4	3-1/2 x 11-1/4
	10'	(3) 2 x 12s	3-1/2 x 9-1/4	3-1/2 x 11-1/4	3-1/2 x 11-1/4	3-1/2 x 11-1/4	3-1/2 x 11-7/8	3-1/2 x 14
	12'	3-1/2 x 11-1/4	3-1/2 x 11-1/4	3-1/2 x 11-7/8	3-1/2 x 14	3-1/2 x 14	5-1/2 x 11-7/8	5-1/2 x 14
	16'	3-1/2 x 14	3-1/2 x 16	3-1/2 x 16	5-1/2 x 14	5-1/2 x 16	5-1/2 x 16	5-1/2 x 18
	18'	3-1/2 x 16	3-1/2 x 18	5-1/2 x 16	5-1/2 x 16	5-1/2 x 18	5-1/2 x 18	5-1/2 x 19-1/4*
No. 2	4'	(1) 2 x 10	(1) 2 x 12	(1) 2 x 12	(2) 2 x 10s	(2) 2 x 10s	(2) 2 x 10s	(2) 2 x 10s
	6'	(2) 2 x 12s	(2) 2 x 12s	(3) 2 x 10s	(3) 2 x 10s	(3) 2 x 12s	(3) 2 x 12s	(3) 2 x 12s
	8'	(3) 2 x 12s	(3) 2 x 12s	3-1/2 x 9-1/4	3-1/2 x 9-1/4	3-1/2 x 9-1/4	3-1/2 x 9-1/4	3-1/2 x 11-1/4
	9'	(3) 2 x 12s	3-1/2 x 9-1/4	3-1/2 x 9-1/4	3-1/2 x 9-1/4	3-1/2 x 11-1/4	3-1/2 x 11-1/4	3-1/2 x 11-1/4
	10'	3-1/2 x 9-1/4	3-1/2 x 9-1/4	3-1/2 x 11-1/4	3-1/2 x 11-1/4	3-1/2 x 11-1/4	3-1/2 x 11-7/8	3-1/2 x 14
	12'	3-1/2 x 11-1/4	3-1/2 x 11-1/4	3-1/2 x 11-7/8	3-1/2 x 14	3-1/2 x 14	5-1/2 x 11-7/8	5-1/2 x 14
	16'	3-1/2 x 14	3-1/2 x 16	3-1/2 x 16	5-1/2 x 14	5-1/2 x 16	5-1/2 x 16	5-1/2 x 18
	18'	3-1/2 x 16	3-1/2 x 18	5-1/2 x 16	5-1/2 x 16	5-1/2 x 18	5-1/2 x 18	5-1/2 x 19-1/4*
No. 3	4'	(2) 2 x 10s	(2) 2 x 10s	(2) 2 x 12s	(2) 2 x 12s	(2) 2 x 12s	(3) 2 x 10s	(3) 2 x 10s
	6'	(3) 2 x 10s	(3) 2 x 12s	(3) 2 x 12s	3-1/2 x 9-1/4	3-1/2 x 9-1/4	3-1/2 x 9-1/4	3-1/2 x 9-1/4
	8'	3-1/2 x 9-1/4	3-1/2 x 9-1/4	3-1/2 x 9-1/4	3-1/2 x 9-1/4	3-1/2 x 9-1/4	3-1/2 x 9-1/4	3-1/2 x 11-1/4
	9'	3-1/2 x 9-1/4	3-1/2 x 9-1/4	3-1/2 x 9-1/4	3-1/2 x 9-1/4	3-1/2 x 11-1/4	3-1/2 x 11-1/4	3-1/2 x 11-1/4
	10'	3-1/2 x 9-1/4	3-1/2 x 9-1/4	3-1/2 x 11-1/4	3-1/2 x 11-1/4	3-1/2 x 11-1/4	3-1/2 x 11-7/8	3-1/2 x 14
	12'	3-1/2 x 11-1/4	3-1/2 x 11-1/4	3-1/2 x 11-7/8	3-1/2 x 14	3-1/2 x 14	5-1/2 x 11-7/8	5-1/2 x 14
	16'	3-1/2 x 14	3-1/2 x 16	3-1/2 x 16	5-1/2 x 14	5-1/2 x 16	5-1/2 x 16	5-1/2 x 18
	18'	3-1/2 x 16	3-1/2 x 18	5-1/2 x 16	5-1/2 x 16	5-1/2 x 18	5-1/2 x 18	5-1/2 x 19-1/4*

Table 9 – 50 psf Ground Snow Load **, 10 psf Dead Load, 1.15 Load Duration Factor								
**Equivalent to a 35 psf Design Roof Snow Load								
Grade	Clear Opening	Span of Supported Roof & Floor Framing						
		16'	20'	24'	28'	32'	36'	40'
No. 1	4'	(1) 2 x 10	(1) 2 x 10	(1) 2 x 12	(1) 2 x 12	(2) 2 x 8s	(2) 2 x 10s	(2) 2 x 10s
	6'	(2) 2 x 10s	(2) 2 x 12s	(2) 2 x 12s	(2) 2 x 12s	(3) 2 x 10s	(3) 2 x 10s	(3) 2 x 12s
	8'	(3) 2 x 10s	(3) 2 x 12s	(3) 2 x 12s	(3) 2 x 12s	3-1/2 x 9-1/4	3-1/2 x 11-1/4	3-1/2 x 11-1/4
	9'	(3) 2 x 12s	(3) 2 x 12s	3-1/2 x 9-1/4	3-1/2 x 11-1/4	3-1/2 x 11-1/4	3-1/2 x 11-1/4	3-1/2 x 14
	10'	(3) 2 x 12s	3-1/2 x 11-1/4	3-1/2 x 11-1/4	3-1/2 x 11-1/4	3-1/2 x 11-7/8	3-1/2 x 14	5-1/2 x 11-1/4
	12'	3-1/2 x 11-1/4	3-1/2 x 11-7/8	3-1/2 x 14	3-1/2 x 14	5-1/2 x 11-7/8	5-1/2 x 14	5-1/2 x 14
	16'	3-1/2 x 16	3-1/2 x 16	5-1/2 x 14	5-1/2 x 16	5-1/2 x 16	5-1/2 x 18	5-1/2 x 18*
	18'	3-1/2 x 18	5-1/2 x 16	5-1/2 x 16	5-1/2 x 18	5-1/2 x 18	5-1/2 x 19-1/4*	5-1/2 x 20-5/8*
No. 2	4'	(1) 2 x 12	(1) 2 x 12	(2) 2 x 8s	(2) 2 x 10s	(2) 2 x 10s	(2) 2 x 10s	(2) 2 x 12s
	6'	(2) 2 x 12s	(2) 2 x 12s	(3) 2 x 10s	(3) 2 x 12s	(3) 2 x 12s	(3) 2 x 12s	(3) 2 x 12s
	8'	(3) 2 x 12s	(3) 2 x 12s	3-1/2 x 9-1/4	3-1/2 x 9-1/4	3-1/2 x 9-1/4	3-1/2 x 11-1/4	3-1/2 x 11-1/4
	9'	3-1/2 x 9-1/4	3-1/2 x 9-1/4	3-1/2 x 9-1/4	3-1/2 x 11-1/4	3-1/2 x 11-1/4	3-1/2 x 11-1/4	3-1/2 x 14
	10'	3-1/2 x 9-1/4	3-1/2 x 11-1/4	3-1/2 x 11-1/4	3-1/2 x 11-1/4	3-1/2 x 11-7/8	3-1/2 x 14	5-1/2 x 11-1/4
	12'	3-1/2 x 11-1/4	3-1/2 x 11-7/8	3-1/2 x 14	3-1/2 x 14	5-1/2 x 11-7/8	5-1/2 x 14	5-1/2 x 14
	16'	3-1/2 x 16	3-1/2 x 16	5-1/2 x 14	5-1/2 x 16	5-1/2 x 16	5-1/2 x 18	5-1/2 x 18*
	18'	3-1/2 x 18	5-1/2 x 16	5-1/2 x 16	5-1/2 x 18	5-1/2 x 18	5-1/2 x 19-1/4*	5-1/2 x 20-5/8*
No. 3	4'	(2) 2 x 10s	(2) 2 x 12s	(2) 2 x 12s	(2) 2 x 12s	(3) 2 x 10s	(3) 2 x 10s	(3) 2 x 12s
	6'	(3) 2 x 12s	(3) 2 x 12s	3-1/2 x 9-1/4	3-1/2 x 9-1/4	3-1/2 x 9-1/4	3-1/2 x 9-1/4	3-1/2 x 9-1/4
	8'	3-1/2 x 9-1/4	3-1/2 x 9-1/4	3-1/2 x 9-1/4	3-1/2 x 9-1/4	3-1/2 x 9-1/4	3-1/2 x 11-1/4	3-1/2 x 11-1/4
	9'	3-1/2 x 9-1/4	3-1/2 x 9-1/4	3-1/2 x 9-1/4	3-1/2 x 11-1/4	3-1/2 x 11-1/4	3-1/2 x 11-1/4	3-1/2 x 14
	10'	3-1/2 x 9-1/4	3-1/2 x 11-1/4	3-1/2 x 11-1/4	3-1/2 x 11-1/4	3-1/2 x 11-7/8	3-1/2 x 14	5-1/2 x 11-1/4
	12'	3-1/2 x 11-1/4	3-1/2 x 11-7/8	3-1/2 x 14	3-1/2 x 14	5-1/2 x 11-7/8	5-1/2 x 14	5-1/2 x 14
	16'	3-1/2 x 16	3-1/2 x 16	5-1/2 x 14	5-1/2 x 16	5-1/2 x 16	5-1/2 x 18	5-1/2 x 18*
	18'	3-1/2 x 18	5-1/2 x 16	5-1/2 x 16	5-1/2 x 18	5-1/2 x 18	5-1/2 x 19-1/4*	5-1/2 x 20-5/8*

(See Requirements for Use on page 7, Key (*) and Notes on page 12, and Example on page 15)

Table 10 – 70 psf Ground Snow Load **, 10 psf Dead Load, 1.15 Load Duration Factor
 **Equivalent to a 49 psf Design Roof Snow Load

Grade	Clear Opening	Span of Supported Roof & Floor Framing						
		16'	20'	24'	28'	32'	36'	40'
No. 1	4'	(1) 2 x 10	(1) 2 x 12	(2) 2 x 8s	(2) 2 x 8s	(2) 2 x 10s	(2) 2 x 10s	(2) 2 x 10s
	6'	(2) 2 x 12s	(2) 2 x 12s	(2) 2 x 12s	(3) 2 x 10s	(3) 2 x 12s	(3) 2 x 12s	(3) 2 x 12s
	8'	(3) 2 x 12s	(3) 2 x 12s	(3) 2 x 12s	3-1/2 x 11-1/4	3-1/2 x 11-1/4	3-1/2 x 11-7/8	5-1/2 x 11-1/4
	9'	(3) 2 x 12s	3-1/2 x 9-1/2	3-1/2 x 11-1/4	3-1/2 x 11-1/4	3-1/2 x 11-7/8	5-1/2 x 11-1/4	5-1/2 x 11-7/8
	10'	3-1/2 x 11-1/4	3-1/2 x 11-1/4	3-1/2 x 11-1/4	3-1/2 x 14	5-1/2 x 11-1/4	5-1/2 x 11-7/8	5-1/2 x 14
	12'	3-1/2 x 11-7/8	3-1/2 x 14	3-1/2 x 14	5-1/2 x 14	5-1/2 x 14	5-1/2 x 16	5-1/2 x 16
	16'	3-1/2 x 16	5-1/2 x 16	5-1/2 x 16	5-1/2 x 16	5-1/2 x 18*	5-1/2 x 19-1/4*	5-1/2 x 20-5/8*
	18'	5-1/2 x 16	5-1/2 x 18	5-1/2 x 18	5-1/2 x 18*	5-1/2 x 20-5/8*	5-1/2 x 22*	5-1/2 x 23-3/8*
No. 2	4'	(1) 2 x 12	(2) 2 x 10s	(2) 2 x 10s	(2) 2 x 10s	(2) 2 x 12s	(2) 2 x 12s	(2) 2 x 12s
	6'	(2) 2 x 12s	(3) 2 x 10s	(3) 2 x 12s	(3) 2 x 12s	(3) 2 x 12s	3-1/2 x 9-1/4	3-1/2 x 9-1/4
	8'	(3) 2 x 12s	3-1/2 x 9-1/4	3-1/2 x 9-1/4	3-1/2 x 11-1/4	3-1/2 x 11-1/4	3-1/2 x 11-7/8	5-1/2 x 11-1/4
	9'	3-1/2 x 9-1/4	3-1/2 x 9-1/2	3-1/2 x 11-1/4	3-1/2 x 11-1/4	3-1/2 x 11-7/8	5-1/2 x 11-1/4	5-1/2 x 11-7/8
	10'	3-1/2 x 11-1/4	3-1/2 x 11-1/4	3-1/2 x 11-1/4	3-1/2 x 14	5-1/2 x 11-1/4	5-1/2 x 11-7/8	5-1/2 x 14
	12'	3-1/2 x 11-7/8	3-1/2 x 14	3-1/2 x 14	5-1/2 x 14	5-1/2 x 14	5-1/2 x 16	5-1/2 x 16
	16'	3-1/2 x 16	5-1/2 x 16	5-1/2 x 16	5-1/2 x 16	5-1/2 x 18*	5-1/2 x 19-1/4*	5-1/2 x 20-5/8*
	18'	5-1/2 x 16	5-1/2 x 18	5-1/2 x 18	5-1/2 x 18*	5-1/2 x 20-5/8*	5-1/2 x 22*	5-1/2 x 23-3/8*
No. 3	4'	(2) 2 x 12s	(2) 2 x 12s	(3) 2 x 10s	(3) 2 x 10s	(3) 2 x 12s	(3) 2 x 12s	(3) 2 x 12s
	6'	(3) 2 x 12s	3-1/2 x 9-1/4	3-1/2 x 9-1/4	3-1/2 x 9-1/4	3-1/2 x 9-1/4	3-1/2 x 9-1/4	3-1/2 x 9-1/4
	8'	3-1/2 x 9-1/4	3-1/2 x 9-1/4	3-1/2 x 9-1/4	3-1/2 x 11-1/4	3-1/2 x 11-1/4	3-1/2 x 11-7/8	5-1/2 x 11-1/4
	9'	3-1/2 x 9-1/4	3-1/2 x 9-1/2	3-1/2 x 11-1/4	3-1/2 x 11-1/4	3-1/2 x 11-7/8	5-1/2 x 11-1/4	5-1/2 x 11-7/8
	10'	3-1/2 x 11-1/4	3-1/2 x 11-1/4	3-1/2 x 11-1/4	3-1/2 x 14	5-1/2 x 11-1/4	5-1/2 x 11-7/8	5-1/2 x 14
	12'	3-1/2 x 11-7/8	3-1/2 x 14	3-1/2 x 14	5-1/2 x 14	5-1/2 x 14	5-1/2 x 16	5-1/2 x 16
	16'	3-1/2 x 16	5-1/2 x 16	5-1/2 x 16	5-1/2 x 16	5-1/2 x 18*	5-1/2 x 19-1/4*	5-1/2 x 20-5/8*
	18'	5-1/2 x 16	5-1/2 x 18	5-1/2 x 18	5-1/2 x 18*	5-1/2 x 20-5/8*	5-1/2 x 22*	5-1/2 x 23-3/8*

Table 11 – 20 psf Live Load, 10 psf Dead Load, 1.25 Load Duration Factor

Grade	Clear Opening	Span of Supported Roof & Floor Framing						
		16'	20'	24'	28'	32'	36'	40'
No. 1	4'	(1) 2 x 8	(1) 2 x 8	(1) 2 x 10	(1) 2 x 10	(1) 2 x 12	(1) 2 x 12	(2) 2 x 8s
	6'	(1) 2 x 12	(2) 2 x 10s	(2) 2 x 10s	(2) 2 x 10s	(2) 2 x 12s	(2) 2 x 12s	(2) 2 x 12s
	8'	(2) 2 x 12s	(2) 2 x 12s	(3) 2 x 10s	(3) 2 x 10s	(3) 2 x 12s	(3) 2 x 12s	(3) 2 x 12s
	9'	(2) 2 x 12s	(3) 2 x 10s	(3) 2 x 12s	(3) 2 x 12s	(3) 2 x 12s	3-1/2 x 9-1/2	3-1/2 x 11-1/4
	10'	(3) 2 x 10s	(3) 2 x 12s	(3) 2 x 12s	3-1/2 x 11-1/4	3-1/2 x 11-1/4	3-1/2 x 11-1/4	3-1/2 x 11-1/4
	12'	(3) 2 x 12s	3-1/2 x 11-1/4	3-1/2 x 11-1/4	3-1/2 x 11-7/8	3-1/2 x 14	3-1/2 x 14	3-1/2 x 14
	16'	3-1/2 x 14	3-1/2 x 16	3-1/2 x 16	3-1/2 x 16	5-1/2 x 14	5-1/2 x 16	5-1/2 x 16
	18'	3-1/2 x 16	3-1/2 x 16	3-1/2 x 18	5-1/2 x 16	5-1/2 x 16	5-1/2 x 16	5-1/2 x 18
No. 2	4'	(1) 2 x 10	(1) 2 x 10	(1) 2 x 12	(1) 2 x 12	(1) 2 x 12	(2) 2 x 10s	(2) 2 x 10s
	6'	(2) 2 x 10s	(2) 2 x 10s	(2) 2 x 12s	(2) 2 x 12s	(3) 2 x 10s	(3) 2 x 10s	(3) 2 x 12s
	8'	(3) 2 x 10s	(3) 2 x 10s	(3) 2 x 12s	(3) 2 x 12s	3-1/2 x 9-1/4	3-1/2 x 9-1/4	3-1/2 x 9-1/4
	9'	(3) 2 x 12s	(3) 2 x 12s	3-1/2 x 9-1/4	3-1/2 x 9-1/4	3-1/2 x 9-1/4	3-1/2 x 9-1/2	3-1/2 x 11-1/4
	10'	(3) 2 x 12s	3-1/2 x 9-1/4	3-1/2 x 9-1/2	3-1/2 x 11-1/4	3-1/2 x 11-1/4	3-1/2 x 11-1/4	3-1/2 x 11-1/4
	12'	3-1/2 x 11-1/4	3-1/2 x 11-1/4	3-1/2 x 11-1/4	3-1/2 x 11-7/8	3-1/2 x 14	3-1/2 x 14	3-1/2 x 14
	16'	3-1/2 x 14	3-1/2 x 16	3-1/2 x 16	3-1/2 x 16	5-1/2 x 14	5-1/2 x 16	5-1/2 x 16
	18'	3-1/2 x 16	3-1/2 x 16	3-1/2 x 18	5-1/2 x 16	5-1/2 x 16	5-1/2 x 16	5-1/2 x 18
No. 3	4'	(1) 2 x 12	(2) 2 x 10s	(2) 2 x 10s	(2) 2 x 10s	(2) 2 x 12s	(2) 2 x 12s	(2) 2 x 12s
	6'	(2) 2 x 12s	(3) 2 x 10s	(3) 2 x 12s	(3) 2 x 12s	(3) 2 x 12s	3-1/2 x 9-1/4	3-1/2 x 9-1/4
	8'	(3) 2 x 12s	3-1/2 x 9-1/4	3-1/2 x 9-1/4	3-1/2 x 9-1/4	3-1/2 x 9-1/4	3-1/2 x 9-1/4	3-1/2 x 9-1/4
	9'	3-1/2 x 9-1/4	3-1/2 x 9-1/4	3-1/2 x 9-1/4	3-1/2 x 9-1/4	3-1/2 x 9-1/4	3-1/2 x 9-1/2	3-1/2 x 11-1/4
	10'	3-1/2 x 9-1/4	3-1/2 x 9-1/4	3-1/2 x 9-1/2	3-1/2 x 11-1/4	3-1/2 x 11-1/4	3-1/2 x 11-1/4	3-1/2 x 11-1/4
	12'	3-1/2 x 11-1/4	3-1/2 x 11-1/4	3-1/2 x 11-1/4	3-1/2 x 11-7/8	3-1/2 x 14	3-1/2 x 14	3-1/2 x 14
	16'	3-1/2 x 14	3-1/2 x 16	3-1/2 x 16	3-1/2 x 16	5-1/2 x 14	5-1/2 x 16	5-1/2 x 16
	18'	3-1/2 x 16	3-1/2 x 16	3-1/2 x 18	5-1/2 x 16	5-1/2 x 16	5-1/2 x 16	5-1/2 x 18

(See Requirements for Use on page 7, Key (*) and Notes on page 12, and Example on page 15)

Table 12 – 20 psf Live Load, 20 psf Dead Load, 1.25 Load Duration Factor

Grade	Clear Opening	Span of Supported Roof & Floor Framing						
		16'	20'	24'	28'	32'	36'	40'
No. 1	4'	(1) 2 x 8	(1) 2 x 10	(1) 2 x 10	(1) 2 x 12	(2) 2 x 8s	(2) 2 x 8s	(2) 2 x 8s
	6'	(2) 2 x 8s	(2) 2 x 10s	(2) 2 x 12s	(2) 2 x 12s	(2) 2 x 12s	(2) 2 x 12s	(3) 2 x 10s
	8'	(2) 2 x 12s	(3) 2 x 10s	(3) 2 x 12s	(3) 2 x 12s	(3) 2 x 12s	3-1/2 x 9-1/4	3-1/2 x 9-1/2
	9'	(3) 2 x 10s	(3) 2 x 12s	(3) 2 x 12s	3-1/2 x 9-1/4	3-1/2 x 11-1/4	3-1/2 x 11-1/4	3-1/2 x 11-1/4
	10'	(3) 2 x 12s	(3) 2 x 12s	3-1/2 x 11-1/4	3-1/2 x 11-1/4	3-1/2 x 11-1/4	3-1/2 x 11-1/4	3-1/2 x 11-7/8
	12'	3-1/2 x 11-1/4	3-1/2 x 11-1/4	3-1/2 x 11-7/8	3-1/2 x 14	3-1/2 x 14	5-1/2 x 11-7/8	5-1/2 x 11-7/8
	16'	3-1/2 x 14	3-1/2 x 16	5-1/2 x 14	5-1/2 x 14	5-1/2 x 16	5-1/2 x 16	5-1/2 x 16
	18'	3-1/2 x 16	3-1/2 x 18	5-1/2 x 16	5-1/2 x 16	5-1/2 x 18	5-1/2 x 18*	5-1/2 x 18*
No. 2	4'	(1) 2 x 10	(1) 2 x 12	(1) 2 x 12	(1) 2 x 12	(2) 2 x 10s	(2) 2 x 10s	(2) 2 x 10s
	6'	(2) 2 x 10s	(2) 2 x 12s	(2) 2 x 12s	(3) 2 x 10s	(3) 2 x 10s	(3) 2 x 12s	(3) 2 x 12s
	8'	(3) 2 x 10s	(3) 2 x 12s	(3) 2 x 12s	3-1/2 x 9-1/4	3-1/2 x 9-1/4	3-1/2 x 9-1/4	3-1/2 x 9-1/2
	9'	(3) 2 x 12s	3-1/2 x 9-1/4	3-1/2 x 9-1/4	3-1/2 x 9-1/4	3-1/2 x 11-1/4	3-1/2 x 11-1/4	3-1/2 x 11-1/4
	10'	3-1/2 x 9-1/4	3-1/2 x 9-1/2	3-1/2 x 11-1/4	3-1/2 x 11-1/4	3-1/2 x 11-1/4	3-1/2 x 11-1/4	3-1/2 x 11-7/8
	12'	3-1/2 x 11-1/4	3-1/2 x 11-1/4	3-1/2 x 11-7/8	3-1/2 x 14	3-1/2 x 14	5-1/2 x 11-7/8	5-1/2 x 11-7/8
	16'	3-1/2 x 14	3-1/2 x 16	5-1/2 x 14	5-1/2 x 14	5-1/2 x 16	5-1/2 x 16	5-1/2 x 16
	18'	3-1/2 x 16	3-1/2 x 18	5-1/2 x 16	5-1/2 x 16	5-1/2 x 18	5-1/2 x 18*	5-1/2 x 18*
No. 3	4'	(2) 2 x 10s	(2) 2 x 10s	(2) 2 x 12s	(2) 2 x 12s	(2) 2 x 12s	(3) 2 x 10s	(3) 2 x 10s
	6'	(3) 2 x 10s	(3) 2 x 12s	(3) 2 x 12s	3-1/2 x 9-1/4	3-1/2 x 9-1/4	3-1/2 x 9-1/4	3-1/2 x 9-1/4
	8'	3-1/2 x 9-1/4	3-1/2 x 9-1/4	3-1/2 x 9-1/4	3-1/2 x 9-1/4	3-1/2 x 9-1/4	3-1/2 x 9-1/4	3-1/2 x 9-1/2
	9'	3-1/2 x 9-1/4	3-1/2 x 9-1/4	3-1/2 x 9-1/4	3-1/2 x 9-1/4	3-1/2 x 11-1/4	3-1/2 x 11-1/4	3-1/2 x 11-1/4
	10'	3-1/2 x 9-1/4	3-1/2 x 9-1/2	3-1/2 x 11-1/4	3-1/2 x 11-1/4	3-1/2 x 11-1/4	3-1/2 x 11-1/4	3-1/2 x 11-7/8
	12'	3-1/2 x 11-1/4	3-1/2 x 11-1/4	3-1/2 x 11-7/8	3-1/2 x 14	3-1/2 x 14	5-1/2 x 11-7/8	5-1/2 x 11-7/8
	16'	3-1/2 x 14	3-1/2 x 16	5-1/2 x 14	5-1/2 x 14	5-1/2 x 16	5-1/2 x 16	5-1/2 x 16
	18'	3-1/2 x 16	3-1/2 x 18	5-1/2 x 16	5-1/2 x 16	5-1/2 x 18	5-1/2 x 18*	5-1/2 x 18*

(See Requirements for Use on page 7, Key (*) and Notes on page 12, and Example on this page)

EXAMPLE: Sliding Glass Door Header – Supporting Roof, Wall & Floor Loads

(See Table 7 on page 12)

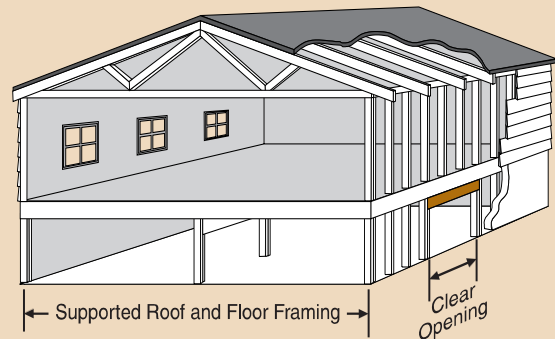

Header size is based on the load transferred from 1/2 the span of the supported roof framing plus a 24" overhang, plus 1/4 the span of the floor framing, plus the wall load.

Ground Snow Load** = 30 psf

(**Equivalent to a 21 psf Design Roof Snow Load)

Dead Load = 10 psf

Load Duration Factor = 1.15

Span of Supported Roof Framing = 20'

Clear Opening = 10'

Southern Pine Header Selected: No.1 Southern Pine Lumber - (3) 2x12s or

(from Table 7)

24F-1.7E (V4) Southern Pine Glulam - 3-1/2" x 9-1/4"

Key

Southern Pine lumber sizes for No.1, No.2 and No.3 grades are shown in regular type with the required number of plies in parentheses. Southern Pine glued laminated timber sizes for a 24F-1.7E (V4) stress class are provided in italics when (4) 2x12s no longer meet design parameters. A 3.0" bearing length is assumed, except for the sizes marked with an asterisk (*) which require a 4.5" bearing length. For other bearing lengths, use the *Allowable Floor Load Tables* (Tables 21-26).

Steps in Using Table 13:

1. Verify the applicability of this table's loading conditions and load duration factor.
2. Find the span of supported floor framing (i.e., sum of the spans of the joists or trusses that frame into the beam) that equals or exceeds the intended application.
3. Find the clear opening.
4. Select product size for the appropriate grade, clear opening and span of supported floor framing.

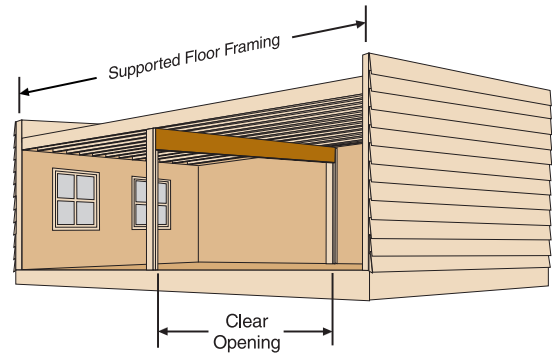

Beam size is based on the load transferred from 1/2 the span of the supported floor framing assuming two simple spans.

Table 13 – 40 psf Live Load, 10 psf Dead Load, 1.00 Load Duration Factor								
Grade	Clear Opening	Span of Supported Floor Framing (Sum of joist spans from both sides of beam)						
		20'	24'	26'	28'	30'	32'	36'
No. 1	8'	(2) 2 x 12s	(2) 2 x 12s	(3) 2 x 10s	(3) 2 x 10s	(3) 2 x 10s	(3) 2 x 12s	(3) 2 x 12s
	9'	(3) 2 x 10s	(3) 2 x 10s	(3) 2 x 12s	(3) 2 x 12s	(3) 2 x 12s	(3) 2 x 12s	(4) 2 x 12s
	10'	(3) 2 x 12s	(3) 2 x 12s	(3) 2 x 12s	(4) 2 x 12s	(4) 2 x 12s	(4) 2 x 12s	(4) 2 x 12s
	11'	(3) 2 x 12s	(4) 2 x 12s	(4) 2 x 12s	(4) 2 x 12s	(4) 2 x 12s	3-1/2 x 14	5-1/2 x 14
	12'	(4) 2 x 12s	(4) 2 x 12s	3-1/2 x 14	3-1/2 x 14	3-1/2 x 16	3-1/2 x 16	5-1/2 x 14
	13'	(4) 2 x 12s	3-1/2 x 14	3-1/2 x 14	3-1/2 x 16	3-1/2 x 16	5-1/2 x 14	5-1/2 x 16
	14'	3-1/2 x 11-7/8	3-1/2 x 14	3-1/2 x 16	5-1/2 x 14	5-1/2 x 14	5-1/2 x 16	5-1/2 x 16
	15'	3-1/2 x 14	3-1/2 x 16	3-1/2 x 16	5-1/2 x 14	5-1/2 x 16	5-1/2 x 16	5-1/2 x 18
	16'	3-1/2 x 14	3-1/2 x 16	5-1/2 x 14	5-1/2 x 16	5-1/2 x 16	5-1/2 x 18	5-1/2 x 19-1/4
	17'	3-1/2 x 16	5-1/2 x 14	5-1/2 x 16	5-1/2 x 16	5-1/2 x 18	5-1/2 x 18	5-1/2 x 19-1/4
18'	3-1/2 x 16	5-1/2 x 16	5-1/2 x 16	5-1/2 x 18	5-1/2 x 18	5-1/2 x 19-1/4	5-1/2 x 20-5/8 *	
No. 2	8'	(3) 2 x 10s	(3) 2 x 12s	(3) 2 x 12s	(3) 2 x 12s	(3) 2 x 12s	(3) 2 x 12s	(4) 2 x 12s
	9'	(3) 2 x 12s	(3) 2 x 12s	(4) 2 x 12s	(4) 2 x 12s	(4) 2 x 12s	(4) 2 x 12s	3-1/2 x 14
	10'	(3) 2 x 12s	(4) 2 x 12s	(4) 2 x 12s	3-1/2 x 11-1/4	3-1/2 x 11-7/8	3-1/2 x 14	3-1/2 x 14
	11'	(4) 2 x 12s	3-1/2 x 11-1/4	3-1/2 x 11-7/8	3-1/2 x 14	3-1/2 x 14	3-1/2 x 14	5-1/2 x 14
	12'	3-1/2 x 11-1/4	3-1/2 x 11-7/8	3-1/2 x 14	3-1/2 x 14	3-1/2 x 16	3-1/2 x 16	5-1/2 x 14
	13'	3-1/2 x 11-1/4	3-1/2 x 14	3-1/2 x 14	3-1/2 x 16	3-1/2 x 16	5-1/2 x 14	5-1/2 x 16
	14'	3-1/2 x 11-7/8	3-1/2 x 14	3-1/2 x 16	5-1/2 x 14	5-1/2 x 14	5-1/2 x 16	5-1/2 x 16
	15'	3-1/2 x 14	3-1/2 x 16	3-1/2 x 16	5-1/2 x 14	5-1/2 x 16	5-1/2 x 16	5-1/2 x 18
	16'	3-1/2 x 14	3-1/2 x 16	5-1/2 x 14	5-1/2 x 16	5-1/2 x 16	5-1/2 x 18	5-1/2 x 19-1/4
	17'	3-1/2 x 16	5-1/2 x 14	5-1/2 x 16	5-1/2 x 16	5-1/2 x 18	5-1/2 x 18	5-1/2 x 19-1/4
18'	3-1/2 x 16	5-1/2 x 16	5-1/2 x 16	5-1/2 x 18	5-1/2 x 18	5-1/2 x 19-1/4	5-1/2 x 20-5/8 *	
No. 3	8'	(4) 2 x 12s	(4) 2 x 12s	3-1/2 x 9-1/4	3-1/2 x 9-1/4	3-1/2 x 11-1/4	3-1/2 x 11-1/4	3-1/2 x 11-1/4
	9'	(4) 2 x 12s	3-1/2 x 9-1/4	3-1/2 x 11-1/4	3-1/2 x 11-1/4	3-1/2 x 11-1/4	3-1/2 x 11-7/8	3-1/2 x 14
	10'	3-1/2 x 9-1/4	3-1/2 x 11-1/4	3-1/2 x 11-1/4	3-1/2 x 11-1/4	3-1/2 x 11-7/8	3-1/2 x 14	3-1/2 x 14
	11'	3-1/2 x 9-1/2	3-1/2 x 11-1/4	3-1/2 x 11-7/8	3-1/2 x 14	3-1/2 x 14	3-1/2 x 14	5-1/2 x 14
	12'	3-1/2 x 11-1/4	3-1/2 x 11-7/8	3-1/2 x 14	3-1/2 x 14	3-1/2 x 16	3-1/2 x 16	5-1/2 x 14
	13'	3-1/2 x 11-1/4	3-1/2 x 14	3-1/2 x 14	3-1/2 x 16	3-1/2 x 16	5-1/2 x 14	5-1/2 x 16
	14'	3-1/2 x 11-7/8	3-1/2 x 14	3-1/2 x 16	5-1/2 x 14	5-1/2 x 14	5-1/2 x 16	5-1/2 x 16
	15'	3-1/2 x 14	3-1/2 x 16	3-1/2 x 16	5-1/2 x 14	5-1/2 x 16	5-1/2 x 16	5-1/2 x 18
	16'	3-1/2 x 14	3-1/2 x 16	5-1/2 x 14	5-1/2 x 16	5-1/2 x 16	5-1/2 x 18	5-1/2 x 19-1/4
	17'	3-1/2 x 16	5-1/2 x 14	5-1/2 x 16	5-1/2 x 16	5-1/2 x 18	5-1/2 x 18	5-1/2 x 19-1/4
18'	3-1/2 x 16	5-1/2 x 16	5-1/2 x 16	5-1/2 x 18	5-1/2 x 18	5-1/2 x 19-1/4	5-1/2 x 20-5/8 *	

(See Requirements for Use on page 7, Key (*) on this page, and Notes and Example on page 17)

Notes for Table 13: Floor Girder Beams

- Table 13 applies to beams carrying only uniformly distributed floor loads from a single floor. For beams supporting additional uniformly distributed loads from a wall and upper floor, use the *Allowable Floor Load Tables* (Tables 21-26).
- See *Assumptions for Table Development* beginning on page 2 for details on design assumptions made to generate these tables.
- Beam size is based on the load transferred from 1/2 the span of the supported floor framing assuming two simple spans.
- Deflection is limited to $\ell/240$ for total load and $\ell/360$ for live load.
- For loading conditions other than those provided in Table 13, use the *Allowable Floor Load Tables* (Tables 21-26). For clear openings other than those provided, use the next larger clear opening shown, or use the *Allowable Floor Load Tables*.
- Tabulated glued laminated timber sizes may be replaced with other glued laminated timber sizes and/or stress classes with equal or greater load capacity (plf); refer to the appropriate *Allowable Floor Load Tables* (Tables 24-26) to determine acceptable options.

Example: Floor Girder Beam – Supporting Floor Loads from a Single Floor Only (See Table 13 on page 16)

Live Load = 40 psf

Dead Load = 10 psf

Load Duration Factor = 1.00

Span of Supported Floor Framing = 11' + 13' = 24'

Clear Opening = 10'

Southern Pine Beam Selected: No.1 Southern Pine Lumber - (3) 2x12s or
(from Table 13) No.2 Southern Pine Lumber - (4) 2x12s or
24F-1.7E (V4) Southern Pine Glulam - 3-1/2" x 11-1/4"

(See *Requirements for Use* on page 7, *Key* (*) on page 16, and *Notes* and *Example* on this page)

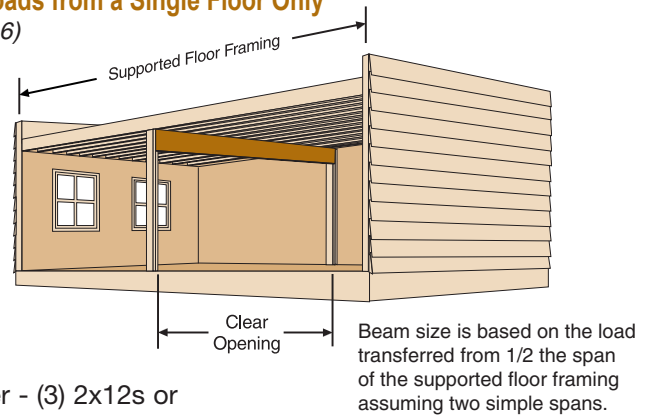

Floor Edge Beams

Notes for Table 14: Floor Edge Beams

- Table 14 applies to beams carrying only uniformly distributed floor loads from a single floor. For beams supporting additional uniformly distributed loads from a wall and upper floor, use the *Allowable Floor Load Tables* (Tables 21-26).
- See *Assumptions for Table Development* beginning on page 2 for details on design assumptions made to generate these tables.
- Beam size is based on the load transferred from 1/2 the span of the supported floor framing.
- Deflection is limited to $\ell/240$ for total load and $\ell/360$ for live load.
- For loading conditions other than those provided in Table 14, use the *Allowable Floor Load Tables* (Tables 21-26). For clear openings other than those provided, use the next larger clear opening shown, or use the *Allowable Floor Load Tables*.
- All (1) ply beams may be replaced with (2) 2x8s of the same or better grade.
- Tabulated glued laminated timber sizes may be replaced with other glued laminated timber sizes and/or stress classes with equal or greater load capacity (plf); refer to the appropriate *Allowable Floor Load Tables* (Tables 24-26) to determine acceptable options.

Example: Floor Edge Beam – Supporting Floor Loads from a Single Floor Only (See Table 14 on page 18)

Live Load = 40 psf

Dead Load = 10 psf

Load Duration Factor = 1.00

Span of Supported Floor Framing = 14'

Clear Opening = 14'

Southern Pine Beam Selected: No.1 Southern Pine Lumber - (3) 2x12s or
(from Table 14) No.2 Southern Pine Lumber - (4) 2x12s or
24F-1.7E (V4) Southern Pine Glulam - 3-1/2" x 11-1/4"

(See *Requirements for Use* on page 7, *Key* on page 18, and *Notes* and *Example* on this page)

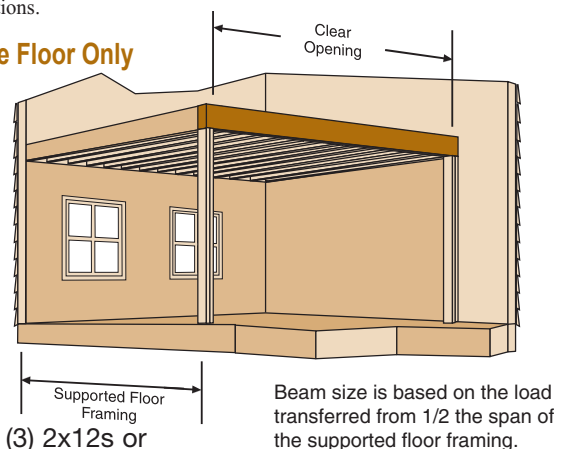

Key

Southern Pine lumber sizes for No.1, No.2 and No.3 grades are shown in regular type with the required number of plies in parentheses. Southern Pine glued laminated timber sizes for a 24F-1.7E (V4) stress class are provided in italics when (4) 2x12s no longer meet design parameters. A 3.0" bearing length is assumed. For other bearing lengths, use the *Allowable Floor Load Tables* (Tables 21-26).

Steps in Using Table 14:

1. Verify the applicability of this table's loading conditions and load duration factor.
2. Find the span of supported floor framing (i.e., span of joists or trusses that frame into the beam) that equals or exceeds the intended application.
3. Find the clear opening.
4. Select product size for the appropriate grade, clear opening and span of supported floor framing.

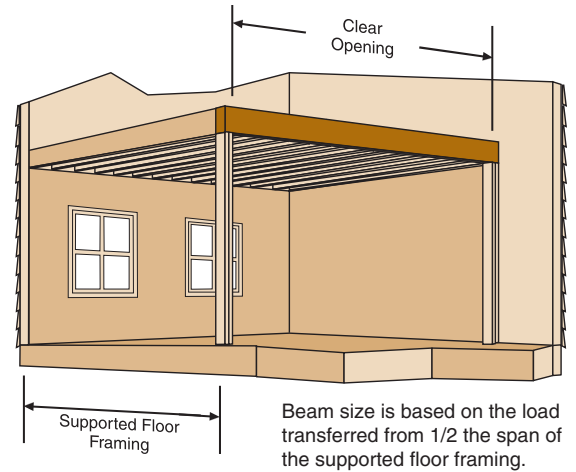

Table 14 – 40 psf Live Load, 10 psf Dead Load, 1.00 Load Duration Factor								
Grade	Clear Opening	Span of Supported Floor Framing						
		10'	12'	14'	16'	18'	20'	22'
No. 1	10'	(2) 2 x 10s	(2) 2 x 12s	(2) 2 x 12s	(2) 2 x 12s	(3) 2 x 10s	(3) 2 x 12s	(3) 2 x 12s
	11'	(2) 2 x 12s	(2) 2 x 12s	(3) 2 x 10s	(3) 2 x 10s	(3) 2 x 12s	(3) 2 x 12s	(3) 2 x 12s
	12'	(2) 2 x 12s	(3) 2 x 10s	(3) 2 x 12s	(3) 2 x 12s	(3) 2 x 12s	(4) 2 x 12s	(4) 2 x 12s
	13'	(3) 2 x 10s	(3) 2 x 12s	(3) 2 x 12s	(3) 2 x 12s	(4) 2 x 12s	(4) 2 x 12s	(4) 2 x 12s
	14'	(3) 2 x 10s	(3) 2 x 12s	(3) 2 x 12s	(4) 2 x 12s	(4) 2 x 12s	<i>3-1/2 x 11-7/8</i>	<i>3-1/2 x 14</i>
	15'	(3) 2 x 12s	(3) 2 x 12s	(4) 2 x 12s	(4) 2 x 12s	<i>3-1/2 x 14</i>	<i>3-1/2 x 14</i>	<i>3-1/2 x 14</i>
	16'	(3) 2 x 12s	(4) 2 x 12s	(4) 2 x 12s	<i>3-1/2 x 14</i>	<i>3-1/2 x 14</i>	<i>3-1/2 x 14</i>	<i>3-1/2 x 14</i>
	17'	(4) 2 x 12s	(4) 2 x 12s	<i>3-1/2 x 14</i>	<i>3-1/2 x 14</i>	<i>3-1/2 x 14</i>	<i>3-1/2 x 16</i>	<i>3-1/2 x 16</i>
	18'	(4) 2 x 12s	<i>3-1/2 x 14</i>	<i>3-1/2 x 14</i>	<i>3-1/2 x 14</i>	<i>3-1/2 x 16</i>	<i>3-1/2 x 16</i>	<i>3-1/2 x 16</i>
	19'	(4) 2 x 12s	<i>3-1/2 x 14</i>	<i>3-1/2 x 14</i>	<i>3-1/2 x 16</i>	<i>3-1/2 x 16</i>	<i>3-1/2 x 16</i>	<i>3-1/2 x 18</i>
20'	<i>3-1/2 x 14</i>	<i>3-1/2 x 14</i>	<i>3-1/2 x 16</i>	<i>3-1/2 x 16</i>	<i>3-1/2 x 16</i>	<i>3-1/2 x 18</i>	<i>3-1/2 x 18</i>	
No. 2	10'	(2) 2 x 12s	(2) 2 x 12s	(3) 2 x 10s	(3) 2 x 12s	(3) 2 x 12s	(3) 2 x 12s	(4) 2 x 12s
	11'	(3) 2 x 10s	(3) 2 x 10s	(3) 2 x 12s	(3) 2 x 12s	(4) 2 x 12s	(4) 2 x 12s	(4) 2 x 12s
	12'	(3) 2 x 10s	(3) 2 x 12s	(3) 2 x 12s	(4) 2 x 12s	(4) 2 x 12s	<i>3-1/2 x 11-1/4</i>	<i>3-1/2 x 11-1/4</i>
	13'	(3) 2 x 12s	(3) 2 x 12s	(4) 2 x 12s	(4) 2 x 12s	<i>3-1/2 x 11-1/4</i>	<i>3-1/2 x 11-1/4</i>	<i>3-1/2 x 11-1/4</i>
	14'	(3) 2 x 12s	(4) 2 x 12s	(4) 2 x 12s	<i>3-1/2 x 11-1/4</i>	<i>3-1/2 x 11-1/4</i>	<i>3-1/2 x 11-7/8</i>	<i>3-1/2 x 14</i>
	15'	(4) 2 x 12s	(4) 2 x 12s	<i>3-1/2 x 11-1/4</i>	<i>3-1/2 x 11-7/8</i>	<i>3-1/2 x 14</i>	<i>3-1/2 x 14</i>	<i>3-1/2 x 14</i>
	16'	(4) 2 x 12s	<i>3-1/2 x 11-1/4</i>	<i>3-1/2 x 11-7/8</i>	<i>3-1/2 x 14</i>	<i>3-1/2 x 14</i>	<i>3-1/2 x 14</i>	<i>3-1/2 x 14</i>
	17'	<i>3-1/2 x 11-1/4</i>	<i>3-1/2 x 14</i>	<i>3-1/2 x 14</i>	<i>3-1/2 x 14</i>	<i>3-1/2 x 14</i>	<i>3-1/2 x 16</i>	<i>3-1/2 x 16</i>
	18'	<i>3-1/2 x 11-7/8</i>	<i>3-1/2 x 14</i>	<i>3-1/2 x 14</i>	<i>3-1/2 x 14</i>	<i>3-1/2 x 16</i>	<i>3-1/2 x 16</i>	<i>3-1/2 x 16</i>
	19'	<i>3-1/2 x 14</i>	<i>3-1/2 x 14</i>	<i>3-1/2 x 14</i>	<i>3-1/2 x 16</i>	<i>3-1/2 x 16</i>	<i>3-1/2 x 16</i>	<i>3-1/2 x 18</i>
20'	<i>3-1/2 x 14</i>	<i>3-1/2 x 14</i>	<i>3-1/2 x 16</i>	<i>3-1/2 x 16</i>	<i>3-1/2 x 16</i>	<i>3-1/2 x 18</i>	<i>3-1/2 x 18</i>	
No. 3	10'	(3) 2 x 12s	(3) 2 x 12s	(4) 2 x 12s	(4) 2 x 12s	<i>3-1/2 x 9-1/4</i>	<i>3-1/2 x 9-1/4</i>	<i>3-1/2 x 9-1/4</i>
	11'	(3) 2 x 12s	(4) 2 x 12s	<i>3-1/2 x 9-1/4</i>	<i>3-1/2 x 9-1/4</i>	<i>3-1/2 x 9-1/4</i>	<i>3-1/2 x 9-1/4</i>	<i>3-1/2 x 9-1/2</i>
	12'	(4) 2 x 12s	<i>3-1/2 x 9-1/4</i>	<i>3-1/2 x 9-1/4</i>	<i>3-1/2 x 9-1/2</i>	<i>3-1/2 x 11-1/4</i>	<i>3-1/2 x 11-1/4</i>	<i>3-1/2 x 11-1/4</i>
	13'	<i>3-1/2 x 9-1/4</i>	<i>3-1/2 x 9-1/4</i>	<i>3-1/2 x 11-1/4</i>	<i>3-1/2 x 11-1/4</i>	<i>3-1/2 x 11-1/4</i>	<i>3-1/2 x 11-1/4</i>	<i>3-1/2 x 11-1/4</i>
	14'	<i>3-1/2 x 9-1/4</i>	<i>3-1/2 x 11-1/4</i>	<i>3-1/2 x 11-1/4</i>	<i>3-1/2 x 11-1/4</i>	<i>3-1/2 x 11-1/4</i>	<i>3-1/2 x 11-7/8</i>	<i>3-1/2 x 14</i>
	15'	<i>3-1/2 x 11-1/4</i>	<i>3-1/2 x 11-1/4</i>	<i>3-1/2 x 11-1/4</i>	<i>3-1/2 x 11-7/8</i>	<i>3-1/2 x 14</i>	<i>3-1/2 x 14</i>	<i>3-1/2 x 14</i>
	16'	<i>3-1/2 x 11-1/4</i>	<i>3-1/2 x 11-1/4</i>	<i>3-1/2 x 11-7/8</i>	<i>3-1/2 x 14</i>	<i>3-1/2 x 14</i>	<i>3-1/2 x 14</i>	<i>3-1/2 x 14</i>
	17'	<i>3-1/2 x 11-1/4</i>	<i>3-1/2 x 14</i>	<i>3-1/2 x 14</i>	<i>3-1/2 x 14</i>	<i>3-1/2 x 14</i>	<i>3-1/2 x 16</i>	<i>3-1/2 x 16</i>
	18'	<i>3-1/2 x 11-7/8</i>	<i>3-1/2 x 14</i>	<i>3-1/2 x 14</i>	<i>3-1/2 x 14</i>	<i>3-1/2 x 16</i>	<i>3-1/2 x 16</i>	<i>3-1/2 x 16</i>
	19'	<i>3-1/2 x 14</i>	<i>3-1/2 x 14</i>	<i>3-1/2 x 14</i>	<i>3-1/2 x 16</i>	<i>3-1/2 x 16</i>	<i>3-1/2 x 16</i>	<i>3-1/2 x 18</i>
20'	<i>3-1/2 x 14</i>	<i>3-1/2 x 14</i>	<i>3-1/2 x 16</i>	<i>3-1/2 x 16</i>	<i>3-1/2 x 16</i>	<i>3-1/2 x 18</i>	<i>3-1/2 x 18</i>	

(See *Requirements for Use* on page 7, *Key* on this page, and *Notes and Example* on page 17)

Key

Southern Pine lumber sizes for No.1, No.2 and No.3 grades are shown in regular type with the required number of plies in parentheses. Southern Pine glued laminated timber sizes for a 24F-1.7E (V4) stress class are provided in italics when (4) 2x12s no longer meet design parameters. A 3.0" bearing length is assumed, except for the sizes marked with an asterisk (*) which require a 4.5" bearing length. For other bearing lengths, use the appropriate *Allowable Roof Load Table* (Tables 27-38).

Steps in Using Tables 15-20:

1. Select the table with loading conditions and load duration factor satisfying the intended application.
2. Find the span of supported roof framing (i.e., sum of the spans of the rafters or trusses that frame into the beam) that equals or exceeds the intended application.
3. Find the clear opening.
4. Select product size for the appropriate grade, clear opening and span of supported roof framing.

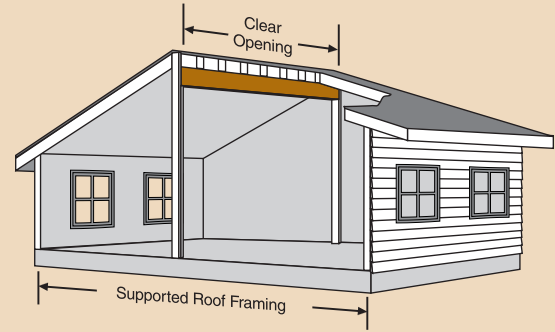

Beam size is based on the load transferred from 1/2 the span of the supported roof framing.

Table 15 – 30 psf Ground Snow Load **, 10 psf Dead Load, 1.15 Load Duration Factor

**Equivalent to a 21 psf Design Roof Snow Load

Grade	Clear Opening	Span of Supported Roof Framing (sum of rafter spans from both sides of beam)						
		16'	20'	24'	28'	32'	36'	40'
No. 1	10'	(2) 2 x 10s	(2) 2 x 10s	(2) 2 x 12s	(2) 2 x 12s	(3) 2 x 10s	(3) 2 x 10s	(3) 2 x 12s
	12'	(2) 2 x 12s	(2) 2 x 12s	(3) 2 x 10s	(3) 2 x 12s	(3) 2 x 12s	(4) 2 x 12s	(4) 2 x 12s
	14'	(3) 2 x 10s	(3) 2 x 12s	(3) 2 x 12s	(4) 2 x 12s	(4) 2 x 12s	3-1/2 x 11-1/4	3-1/2 x 11-1/4
	16'	(3) 2 x 12s	(3) 2 x 12s	(4) 2 x 12s	3-1/2 x 11-1/4	3-1/2 x 11-7/8	3-1/2 x 11-7/8	3-1/2 x 14
	18'	(3) 2 x 12s	(4) 2 x 12s	3-1/2 x 11-7/8	3-1/2 x 14	3-1/2 x 14	3-1/2 x 14	3-1/2 x 14
	20'	(4) 2 x 12s	3-1/2 x 14	3-1/2 x 14	3-1/2 x 14	3-1/2 x 16	3-1/2 x 16	5-1/2 x 14
	22'	3-1/2 x 14	3-1/2 x 14	3-1/2 x 16	3-1/2 x 16	3-1/2 x 16	3-1/2 x 18	5-1/2 x 16
	24'	3-1/2 x 14	3-1/2 x 16	3-1/2 x 16	3-1/2 x 18	3-1/2 x 18	5-1/2 x 16	5-1/2 x 16
No. 2	10'	(2) 2 x 10s	(2) 2 x 12s	(3) 2 x 10s	(3) 2 x 12s	(3) 2 x 12s	(3) 2 x 12s	(4) 2 x 12s
	12'	(3) 2 x 10s	(3) 2 x 12s	(3) 2 x 12s	(4) 2 x 12s	(4) 2 x 12s	3-1/2 x 9-1/4	3-1/2 x 9-1/2
	14'	(3) 2 x 12s	(4) 2 x 12s	(4) 2 x 12s	3-1/2 x 9-1/2	3-1/2 x 11-1/4	3-1/2 x 11-1/4	3-1/2 x 11-1/4
	16'	(4) 2 x 12s	(4) 2 x 12s	3-1/2 x 11-1/4	3-1/2 x 11-1/4	3-1/2 x 11-7/8	3-1/2 x 11-7/8	3-1/2 x 14
	18'	(4) 2 x 12s	3-1/2 x 11-1/4	3-1/2 x 11-7/8	3-1/2 x 14	3-1/2 x 14	3-1/2 x 14	3-1/2 x 14
	20'	3-1/2 x 11-1/4	3-1/2 x 14	3-1/2 x 14	3-1/2 x 14	3-1/2 x 16	3-1/2 x 16	5-1/2 x 14
	22'	3-1/2 x 14	3-1/2 x 14	3-1/2 x 16	3-1/2 x 16	3-1/2 x 16	3-1/2 x 18	5-1/2 x 16
	24'	3-1/2 x 14	3-1/2 x 16	3-1/2 x 16	3-1/2 x 18	3-1/2 x 18	5-1/2 x 16	5-1/2 x 16
No. 3	10'	(3) 2 x 10s	(3) 2 x 12s	(4) 2 x 12s	(4) 2 x 12s	3-1/2 x 9-1/4	3-1/2 x 9-1/4	3-1/2 x 9-1/4
	12'	(3) 2 x 12s	(4) 2 x 12s	3-1/2 x 9-1/4	3-1/2 x 9-1/4	3-1/2 x 9-1/4	3-1/2 x 9-1/4	3-1/2 x 9-1/2
	14'	3-1/2 x 9-1/4	3-1/2 x 9-1/4	3-1/2 x 9-1/4	3-1/2 x 9-1/2	3-1/2 x 11-1/4	3-1/2 x 11-1/4	3-1/2 x 11-1/4
	16'	3-1/2 x 9-1/4	3-1/2 x 11-1/4	3-1/2 x 11-1/4	3-1/2 x 11-1/4	3-1/2 x 11-7/8	3-1/2 x 11-7/8	3-1/2 x 14
	18'	3-1/2 x 11-1/4	3-1/2 x 11-1/4	3-1/2 x 11-7/8	3-1/2 x 14	3-1/2 x 14	3-1/2 x 14	3-1/2 x 14
	20'	3-1/2 x 11-1/4	3-1/2 x 14	3-1/2 x 14	3-1/2 x 14	3-1/2 x 16	3-1/2 x 16	5-1/2 x 14
	22'	3-1/2 x 14	3-1/2 x 14	3-1/2 x 16	3-1/2 x 16	3-1/2 x 16	3-1/2 x 18	5-1/2 x 16
	24'	3-1/2 x 14	3-1/2 x 16	3-1/2 x 16	3-1/2 x 18	3-1/2 x 18	5-1/2 x 16	5-1/2 x 16

(See *Requirements for Use* on page 7, *Key* and *Notes* on this page, and *Example* on page 22)

Notes for Tables 15 - 20: Roof Ridge Beams

- Tables 15-20 apply to beams carrying only uniformly distributed roof loads.
- See *Assumptions for Table Development* beginning on page 2 for details on design assumptions made to generate these tables.
- Beam size is based on the load transferred from 1/2 the span of the supported roof framing. Calculations assume the worst case of simple- or continuous-span glued laminated timber, but only simple-span Southern Pine lumber beams.
- Deflection is limited to $L/180$ for total load and $L/240$ for live load.
- Design Roof Snow Loads have been derived by reducing Ground Snow Loads in accordance with *ASCE 7-10*, Section 7.3. This results in an equivalent balanced Design Roof Snow Load of 0.70 times the Ground Snow Load, with a required minimum of 20 psf (pounds per square foot). Unbalanced snow loads, drifting or rain-on-snow surcharges have not been considered. Roof live load reductions have not been taken.
- For loading conditions other than those provided in Tables 15-20, use another table in this section with higher loading conditions than required, or use the *Allowable Roof Load Table* with the corresponding load duration factor (Tables 27-38). For clear openings other than those provided, use the next larger clear opening shown, or use the appropriate *Allowable Roof Load Table*.
- All (1) ply lumber headers may be replaced with (2) 2x8s of the same or better grade.
- Tabulated glued laminated timber sizes may be replaced with other glued laminated timber sizes and/or stress classes with equal or greater load capacity (plf); refer to the appropriate *Allowable Roof Load Tables* (Tables 30-32 or 36-38) to determine acceptable options.

Table 16 – 40 psf Ground Snow Load **, 10 psf Dead Load, 1.15 Load Duration Factor
**Equivalent to a 28 psf Design Roof Snow Load

Grade	Clear Opening	Span of Supported Roof Framing (sum of rafter spans from both sides of beam)						
		16'	20'	24'	28'	32'	36'	40'
No. 1	10'	(2) 2 x 10s	(2) 2 x 12s	(2) 2 x 12s	(3) 2 x 10s	(3) 2 x 12s	(3) 2 x 12s	(3) 2 x 12s
	12'	(2) 2 x 12s	(3) 2 x 10s	(3) 2 x 12s	(3) 2 x 12s	(4) 2 x 12s	(4) 2 x 12s	3-1/2 x 11-1/4
	14'	(3) 2 x 12s	(3) 2 x 12s	(4) 2 x 12s	(4) 2 x 12s	3-1/2 x 11-1/4	3-1/2 x 11-7/8	3-1/2 x 14
	16'	(3) 2 x 12s	(4) 2 x 12s	3-1/2 x 11-1/4	3-1/2 x 11-7/8	3-1/2 x 14	3-1/2 x 14	3-1/2 x 14
	18'	(4) 2 x 12s	3-1/2 x 11-7/8	3-1/2 x 14	3-1/2 x 14	3-1/2 x 14	5-1/2 x 14	5-1/2 x 14
	20'	3-1/2 x 14	3-1/2 x 14	3-1/2 x 14	3-1/2 x 16	3-1/2 x 16	5-1/2 x 14	5-1/2 x 16
	22'	3-1/2 x 14	3-1/2 x 16	3-1/2 x 16	3-1/2 x 16	5-1/2 x 16	5-1/2 x 16	5-1/2 x 16
	24'	3-1/2 x 16	3-1/2 x 16	3-1/2 x 18	5-1/2 x 16	5-1/2 x 16	5-1/2 x 18	5-1/2 x 18
No. 2	10'	(2) 2 x 12s	(3) 2 x 10s	(3) 2 x 12s	(3) 2 x 12s	(4) 2 x 12s	(4) 2 x 12s	(4) 2 x 12s
	12'	(3) 2 x 12s	(3) 2 x 12s	(4) 2 x 12s	(4) 2 x 12s	3-1/2 x 9-1/4	3-1/2 x 11-1/4	3-1/2 x 11-1/4
	14'	(3) 2 x 12s	(4) 2 x 12s	3-1/2 x 11-1/4	3-1/2 x 11-1/4	3-1/2 x 11-1/4	3-1/2 x 11-7/8	3-1/2 x 14
	16'	(4) 2 x 12s	3-1/2 x 11-1/4	3-1/2 x 11-1/4	3-1/2 x 11-7/8	3-1/2 x 14	3-1/2 x 14	3-1/2 x 14
	18'	3-1/2 x 11-1/4	3-1/2 x 11-7/8	3-1/2 x 14	3-1/2 x 14	3-1/2 x 14	5-1/2 x 14	5-1/2 x 14
	20'	3-1/2 x 14	3-1/2 x 14	3-1/2 x 14	3-1/2 x 16	3-1/2 x 16	5-1/2 x 14	5-1/2 x 16
	22'	3-1/2 x 14	3-1/2 x 16	3-1/2 x 16	3-1/2 x 16	5-1/2 x 16	5-1/2 x 16	5-1/2 x 16
	24'	3-1/2 x 16	3-1/2 x 16	3-1/2 x 18	5-1/2 x 16	5-1/2 x 16	5-1/2 x 18	5-1/2 x 18
No. 3	10'	(3) 2 x 12s	(4) 2 x 12s	(4) 2 x 12s	3-1/2 x 9-1/4	3-1/2 x 9-1/4	3-1/2 x 9-1/4	3-1/2 x 9-1/4
	12'	(4) 2 x 12s	3-1/2 x 9-1/4	3-1/2 x 9-1/4	3-1/2 x 9-1/4	3-1/2 x 9-1/4	3-1/2 x 11-1/4	3-1/2 x 11-1/4
	14'	3-1/2 x 9-1/4	3-1/2 x 9-1/4	3-1/2 x 11-1/4	3-1/2 x 11-1/4	3-1/2 x 11-1/4	3-1/2 x 11-7/8	3-1/2 x 14
	16'	3-1/2 x 11-1/4	3-1/2 x 11-1/4	3-1/2 x 11-1/4	3-1/2 x 11-7/8	3-1/2 x 14	3-1/2 x 14	3-1/2 x 14
	18'	3-1/2 x 11-1/4	3-1/2 x 11-7/8	3-1/2 x 14	3-1/2 x 14	3-1/2 x 14	5-1/2 x 14	5-1/2 x 14
	20'	3-1/2 x 14	3-1/2 x 14	3-1/2 x 14	3-1/2 x 16	3-1/2 x 16	5-1/2 x 14	5-1/2 x 16
	22'	3-1/2 x 14	3-1/2 x 16	3-1/2 x 16	3-1/2 x 16	5-1/2 x 16	5-1/2 x 16	5-1/2 x 16
	24'	3-1/2 x 16	3-1/2 x 16	3-1/2 x 18	5-1/2 x 16	5-1/2 x 16	5-1/2 x 18	5-1/2 x 18

Table 17 – 50 psf Ground Snow Load **, 10 psf Dead Load, 1.15 Load Duration Factor
**Equivalent to a 35 psf Design Roof Snow Load

Grade	Clear Opening	Span of Supported Roof Framing (sum of rafter spans from both sides of beam)						
		16'	20'	24'	28'	32'	36'	40'
No. 1	10'	(2) 2 x 12s	(2) 2 x 12s	(3) 2 x 10s	(3) 2 x 12s	(3) 2 x 12s	(4) 2 x 12s	(4) 2 x 12s
	12'	(3) 2 x 10s	(3) 2 x 12s	(3) 2 x 12s	(4) 2 x 12s	(4) 2 x 12s	3-1/2 x 11-1/4	3-1/2 x 14
	14'	(3) 2 x 12s	(4) 2 x 12s	(4) 2 x 12s	3-1/2 x 11-1/4	3-1/2 x 11-7/8	3-1/2 x 14	5-1/2 x 11-7/8
	16'	(4) 2 x 12s	3-1/2 x 11-1/4	3-1/2 x 11-7/8	3-1/2 x 14	3-1/2 x 14	5-1/2 x 14	5-1/2 x 14
	18'	3-1/2 x 11-7/8	3-1/2 x 14	3-1/2 x 14	3-1/2 x 14	5-1/2 x 14	5-1/2 x 14	5-1/2 x 16
	20'	3-1/2 x 14	3-1/2 x 14	3-1/2 x 16	5-1/2 x 14	5-1/2 x 14	5-1/2 x 16	5-1/2 x 18
	22'	3-1/2 x 16	3-1/2 x 16	3-1/2 x 18	5-1/2 x 16	5-1/2 x 16	5-1/2 x 18	5-1/2 x 19-1/4 *
	24'	3-1/2 x 16	3-1/2 x 18	5-1/2 x 16	5-1/2 x 16	5-1/2 x 18	5-1/2 x 19-1/4 *	5-1/2 x 20-5/8*
No. 2	10'	(3) 2 x 10s	(3) 2 x 12s	(3) 2 x 12s	(4) 2 x 12s	(4) 2 x 12s	3-1/2 x 9-1/4	3-1/2 x 11-1/4
	12'	(3) 2 x 12s	(4) 2 x 12s	(4) 2 x 12s	3-1/2 x 9-1/2	3-1/2 x 11-1/4	3-1/2 x 11-1/4	3-1/2 x 14
	14'	(4) 2 x 12s	3-1/2 x 11-1/4	3-1/2 x 11-1/4	3-1/2 x 11-1/4	3-1/2 x 11-7/8	3-1/2 x 14	5-1/2 x 11-7/8
	16'	3-1/2 x 11-1/4	3-1/2 x 11-1/4	3-1/2 x 11-7/8	3-1/2 x 14	3-1/2 x 14	5-1/2 x 14	5-1/2 x 14
	18'	3-1/2 x 11-7/8	3-1/2 x 14	3-1/2 x 14	3-1/2 x 14	5-1/2 x 14	5-1/2 x 14	5-1/2 x 16
	20'	3-1/2 x 14	3-1/2 x 14	3-1/2 x 16	5-1/2 x 14	5-1/2 x 14	5-1/2 x 16	5-1/2 x 18
	22'	3-1/2 x 16	3-1/2 x 16	3-1/2 x 18	5-1/2 x 16	5-1/2 x 16	5-1/2 x 18	5-1/2 x 19-1/4 *
	24'	3-1/2 x 16	3-1/2 x 18	5-1/2 x 16	5-1/2 x 16	5-1/2 x 18	5-1/2 x 19-1/4 *	5-1/2 x 20-5/8*
No. 3	10'	(4) 2 x 12s	(4) 2 x 12s	3-1/2 x 9-1/4	3-1/2 x 9-1/4	3-1/2 x 9-1/4	3-1/2 x 9-1/4	3-1/2 x 11-1/4
	12'	3-1/2 x 9-1/4	3-1/2 x 9-1/4	3-1/2 x 9-1/4	3-1/2 x 9-1/2	3-1/2 x 11-1/4	3-1/2 x 11-1/4	3-1/2 x 14
	14'	3-1/2 x 9-1/4	3-1/2 x 11-1/4	3-1/2 x 11-1/4	3-1/2 x 11-1/4	3-1/2 x 11-7/8	3-1/2 x 14	5-1/2 x 11-7/8
	16'	3-1/2 x 11-1/4	3-1/2 x 11-1/4	3-1/2 x 11-7/8	3-1/2 x 14	3-1/2 x 14	5-1/2 x 14	5-1/2 x 14
	18'	3-1/2 x 11-7/8	3-1/2 x 14	3-1/2 x 14	3-1/2 x 14	5-1/2 x 14	5-1/2 x 14	5-1/2 x 16
	20'	3-1/2 x 14	3-1/2 x 14	3-1/2 x 16	5-1/2 x 14	5-1/2 x 14	5-1/2 x 16	5-1/2 x 18
	22'	3-1/2 x 16	3-1/2 x 16	3-1/2 x 18	5-1/2 x 16	5-1/2 x 16	5-1/2 x 18	5-1/2 x 19-1/4 *
	24'	3-1/2 x 16	3-1/2 x 18	5-1/2 x 16	5-1/2 x 16	5-1/2 x 18	5-1/2 x 19-1/4 *	5-1/2 x 20-5/8*

(See Requirements for Use on page 7, Key (*) and Notes on page 19, and Example on page 22)

Table 18 – 70 psf Ground Snow Load **, 10 psf Dead Load, 1.15 Load Duration Factor
**Equivalent to a 49 psf Design Roof Snow Load

Grade	Clear Opening	Span of Supported Roof Framing (sum of rafter spans from both sides of beam)						
		16'	20'	24'	28'	32'	36'	40'
No. 1	10'	(3) 2 x 10s	(3) 2 x 12s	(3) 2 x 12s	(4) 2 x 12s	(4) 2 x 12s	(4) 2 x 12s	3-1/2 x 14
	12'	(3) 2 x 12s	(4) 2 x 12s	(4) 2 x 12s	3-1/2 x 11-1/4	3-1/2 x 14	5-1/2 x 11-7/8	5-1/2 x 14
	14'	(4) 2 x 12s	3-1/2 x 11-1/4	3-1/2 x 11-7/8	3-1/2 x 14	5-1/2 x 14	5-1/2 x 14	5-1/2 x 16
	16'	3-1/2 x 11-7/8	3-1/2 x 14	3-1/2 x 14	5-1/2 x 14	5-1/2 x 14	5-1/2 x 16	5-1/2 x 18
	18'	3-1/2 x 14	3-1/2 x 14	5-1/2 x 14	5-1/2 x 14	5-1/2 x 16	5-1/2 x 18	5-1/2 x 19-1/4*
	20'	3-1/2 x 16	3-1/2 x 16	5-1/2 x 16	5-1/2 x 16	5-1/2 x 18	5-1/2 x 19-1/4*	5-1/2 x 22*
	22'	3-1/2 x 16	5-1/2 x 16	5-1/2 x 16	5-1/2 x 18	5-1/2 x 19-1/4*	5-1/2 x 22*	5-1/2 x 23-3/8*
	24'	3-1/2 x 18	5-1/2 x 16	5-1/2 x 18	5-1/2 x 19-1/4*	5-1/2 x 20-5/8*	5-1/2 x 23-3/8*	----
No. 2	10'	(3) 2 x 12s	(3) 2 x 12s	(4) 2 x 12s	3-1/2 x 9-1/2	3-1/2 x 11-1/4	3-1/2 x 11-7/8	3-1/2 x 14
	12'	(4) 2 x 12s	3-1/2 x 9-1/2	3-1/2 x 11-1/4	3-1/2 x 11-1/4	3-1/2 x 14	5-1/2 x 11-7/8	5-1/2 x 14
	14'	3-1/2 x 11-1/4	3-1/2 x 11-1/4	3-1/2 x 11-7/8	3-1/2 x 14	5-1/2 x 14	5-1/2 x 14	5-1/2 x 16
	16'	3-1/2 x 11-7/8	3-1/2 x 14	3-1/2 x 14	5-1/2 x 14	5-1/2 x 14	5-1/2 x 16	5-1/2 x 18
	18'	3-1/2 x 14	3-1/2 x 14	5-1/2 x 14	5-1/2 x 14	5-1/2 x 16	5-1/2 x 18	5-1/2 x 19-1/4*
	20'	3-1/2 x 16	3-1/2 x 16	5-1/2 x 16	5-1/2 x 16	5-1/2 x 18	5-1/2 x 19-1/4*	5-1/2 x 22*
	22'	3-1/2 x 16	5-1/2 x 16	5-1/2 x 16	5-1/2 x 18	5-1/2 x 19-1/4*	5-1/2 x 22*	5-1/2 x 23-3/8*
	24'	3-1/2 x 18	5-1/2 x 16	5-1/2 x 18	5-1/2 x 19-1/4*	5-1/2 x 20-5/8*	5-1/2 x 23-3/8*	----
No. 3	10'	(4) 2 x 12s	3-1/2 x 9-1/4	3-1/2 x 9-1/4	3-1/2 x 9-1/2	3-1/2 x 11-1/4	3-1/2 x 11-7/8	3-1/2 x 14
	12'	3-1/2 x 9-1/4	3-1/2 x 9-1/2	3-1/2 x 11-1/4	3-1/2 x 11-1/4	3-1/2 x 14	5-1/2 x 11-7/8	5-1/2 x 14
	14'	3-1/2 x 11-1/4	3-1/2 x 11-1/4	3-1/2 x 11-7/8	3-1/2 x 14	5-1/2 x 14	5-1/2 x 14	5-1/2 x 16
	16'	3-1/2 x 11-7/8	3-1/2 x 14	3-1/2 x 14	5-1/2 x 14	5-1/2 x 14	5-1/2 x 16	5-1/2 x 18
	18'	3-1/2 x 14	3-1/2 x 14	5-1/2 x 14	5-1/2 x 14	5-1/2 x 16	5-1/2 x 18	5-1/2 x 19-1/4*
	20'	3-1/2 x 16	3-1/2 x 16	5-1/2 x 16	5-1/2 x 16	5-1/2 x 18	5-1/2 x 19-1/4*	5-1/2 x 22*
	22'	3-1/2 x 16	5-1/2 x 16	5-1/2 x 16	5-1/2 x 18	5-1/2 x 19-1/4*	5-1/2 x 22*	5-1/2 x 23-3/8*
	24'	3-1/2 x 18	5-1/2 x 16	5-1/2 x 18	5-1/2 x 19-1/4*	5-1/2 x 20-5/8*	5-1/2 x 23-3/8*	----

Table 19 – 20 psf Live Load, 10 psf Dead Load, 1.25 Load Duration Factor

Grade	Clear Opening	Span of Supported Roof Framing (sum of rafter spans from both sides of beam)						
		16'	20'	24'	28'	32'	36'	40'
No. 1	10'	(1) 2 x 12	(2) 2 x 10s	(2) 2 x 12s	(2) 2 x 12s	(2) 2 x 12s	(3) 2 x 10s	(3) 2 x 10s
	12'	(2) 2 x 10s	(2) 2 x 12s	(3) 2 x 10s	(3) 2 x 10s	(3) 2 x 12s	(3) 2 x 12s	(3) 2 x 12s
	14'	(2) 2 x 12s	(3) 2 x 10s	(3) 2 x 12s	(3) 2 x 12s	(4) 2 x 12s	(4) 2 x 12s	3-1/2 x 11-1/4
	16'	(3) 2 x 10s	(3) 2 x 12s	(4) 2 x 12s	(4) 2 x 12s	3-1/2 x 11-1/4	3-1/2 x 11-7/8	3-1/2 x 14
	18'	(3) 2 x 12s	(4) 2 x 12s	(4) 2 x 12s	3-1/2 x 14	3-1/2 x 14	3-1/2 x 14	3-1/2 x 14
	20'	(4) 2 x 12s	3-1/2 x 14	3-1/2 x 14	3-1/2 x 14	3-1/2 x 14	3-1/2 x 16	3-1/2 x 16
	22'	(4) 2 x 12s	3-1/2 x 14	3-1/2 x 14	3-1/2 x 16	3-1/2 x 16	3-1/2 x 16	5-1/2 x 16
	24'	3-1/2 x 14	3-1/2 x 16	3-1/2 x 16	3-1/2 x 16	3-1/2 x 18	5-1/2 x 16	5-1/2 x 16
No. 2	10'	(2) 2 x 10s	(2) 2 x 12s	(2) 2 x 12s	(3) 2 x 10s	(3) 2 x 12s	(3) 2 x 12s	(3) 2 x 12s
	12'	(2) 2 x 12s	(3) 2 x 10s	(3) 2 x 12s	(3) 2 x 12s	(4) 2 x 12s	(4) 2 x 12s	(4) 2 x 12s
	14'	(3) 2 x 10s	(3) 2 x 12s	(4) 2 x 12s	(4) 2 x 12s	3-1/2 x 11-1/4	3-1/2 x 11-1/4	3-1/2 x 11-1/4
	16'	(3) 2 x 12s	(4) 2 x 12s	3-1/2 x 11-1/4	3-1/2 x 11-1/4	3-1/2 x 11-1/4	3-1/2 x 11-7/8	3-1/2 x 14
	18'	(4) 2 x 12s	3-1/2 x 11-1/4	3-1/2 x 11-7/8	3-1/2 x 14	3-1/2 x 14	3-1/2 x 14	3-1/2 x 14
	20'	3-1/2 x 11-1/4	3-1/2 x 14	3-1/2 x 14	3-1/2 x 14	3-1/2 x 14	3-1/2 x 16	3-1/2 x 16
	22'	3-1/2 x 14	3-1/2 x 14	3-1/2 x 14	3-1/2 x 16	3-1/2 x 16	3-1/2 x 16	5-1/2 x 16
	24'	3-1/2 x 14	3-1/2 x 16	3-1/2 x 16	3-1/2 x 16	3-1/2 x 18	5-1/2 x 16	5-1/2 x 16
No. 3	10'	(3) 2 x 10s	(3) 2 x 12s	(3) 2 x 12s	(4) 2 x 12s	(4) 2 x 12s	3-1/2 x 9-1/4	3-1/2 x 9-1/4
	12'	(3) 2 x 12s	(4) 2 x 12s	(4) 2 x 12s	3-1/2 x 9-1/4	3-1/2 x 9-1/4	3-1/2 x 9-1/4	3-1/2 x 9-1/4
	14'	(4) 2 x 12s	3-1/2 x 9-1/4	3-1/2 x 9-1/4	3-1/2 x 9-1/2	3-1/2 x 11-1/4	3-1/2 x 11-1/4	3-1/2 x 11-1/4
	16'	3-1/2 x 9-1/4	3-1/2 x 11-1/4	3-1/2 x 11-1/4	3-1/2 x 11-1/4	3-1/2 x 11-1/4	3-1/2 x 11-7/8	3-1/2 x 14
	18'	3-1/2 x 11-1/4	3-1/2 x 11-1/4	3-1/2 x 11-7/8	3-1/2 x 14	3-1/2 x 14	3-1/2 x 14	3-1/2 x 14
	20'	3-1/2 x 11-1/4	3-1/2 x 14	3-1/2 x 14	3-1/2 x 14	3-1/2 x 14	3-1/2 x 16	3-1/2 x 16
	22'	3-1/2 x 14	3-1/2 x 14	3-1/2 x 14	3-1/2 x 16	3-1/2 x 16	3-1/2 x 16	5-1/2 x 16
	24'	3-1/2 x 14	3-1/2 x 16	3-1/2 x 16	3-1/2 x 16	3-1/2 x 18	5-1/2 x 16	5-1/2 x 16

(See Requirements for Use on page 7, Key (*) and Notes on page 19, and Example on page 22)

Table 20 – 20 psf Live Load, 20 psf Dead Load, 1.25 Load Duration Factor								
Grade	Clear Opening	Span of Supported Roof Framing (sum of rafter spans from both sides of beam)						
		16'	20'	24'	28'	32'	36'	40'
No. 1	10'	(2) 2 x 10s	(2) 2 x 12s	(2) 2 x 12s	(3) 2 x 10s	(3) 2 x 12s	(3) 2 x 12s	(3) 2 x 12s
	12'	(2) 2 x 12s	(3) 2 x 10s	(3) 2 x 12s	(3) 2 x 12s	(4) 2 x 12s	(4) 2 x 12s	(4) 2 x 12s
	14'	(3) 2 x 12s	(3) 2 x 12s	(4) 2 x 12s	(4) 2 x 12s	3-1/2 x 11-1/4	3-1/2 x 11-1/4	3-1/2 x 11-7/8
	16'	(3) 2 x 12s	(4) 2 x 12s	3-1/2 x 11-1/4	3-1/2 x 11-7/8	3-1/2 x 14	3-1/2 x 14	5-1/2 x 11-7/8
	18'	(4) 2 x 12s	3-1/2 x 11-7/8	3-1/2 x 14	3-1/2 x 14	3-1/2 x 14	5-1/2 x 14	5-1/2 x 14
	20'	3-1/2 x 14	3-1/2 x 14	3-1/2 x 14	3-1/2 x 16	5-1/2 x 14	5-1/2 x 14	5-1/2 x 16
	22'	3-1/2 x 14	3-1/2 x 16	3-1/2 x 16	5-1/2 x 14	5-1/2 x 16	5-1/2 x 16	5-1/2 x 16
	24'	3-1/2 x 16	3-1/2 x 16	3-1/2 x 18	5-1/2 x 16	5-1/2 x 16	5-1/2 x 18	5-1/2 x 18
No. 2	10'	(2) 2 x 12s	(3) 2 x 10s	(3) 2 x 12s	(3) 2 x 12s	(3) 2 x 12s	(4) 2 x 12s	(4) 2 x 12s
	12'	(3) 2 x 10s	(3) 2 x 12s	(4) 2 x 12s	(4) 2 x 12s	3-1/2 x 9-1/2	3-1/2 x 11-1/4	3-1/2 x 11-1/4
	14'	(3) 2 x 12s	(4) 2 x 12s	3-1/2 x 11-1/4	3-1/2 x 11-1/4	3-1/2 x 11-1/4	3-1/2 x 11-1/4	3-1/2 x 11-7/8
	16'	(4) 2 x 12s	3-1/2 x 11-1/4	3-1/2 x 11-1/4	3-1/2 x 11-7/8	3-1/2 x 14	3-1/2 x 14	5-1/2 x 11-7/8
	18'	3-1/2 x 11-1/4	3-1/2 x 11-7/8	3-1/2 x 14	3-1/2 x 14	3-1/2 x 14	5-1/2 x 14	5-1/2 x 14
	20'	3-1/2 x 14	3-1/2 x 14	3-1/2 x 14	3-1/2 x 16	5-1/2 x 14	5-1/2 x 14	5-1/2 x 16
	22'	3-1/2 x 14	3-1/2 x 16	3-1/2 x 16	5-1/2 x 14	5-1/2 x 16	5-1/2 x 16	5-1/2 x 16
	24'	3-1/2 x 16	3-1/2 x 16	3-1/2 x 18	5-1/2 x 16	5-1/2 x 16	5-1/2 x 18	5-1/2 x 18
No. 3	10'	(3) 2 x 12s	(4) 2 x 12s	(4) 2 x 12s	3-1/2 x 9-1/4	3-1/2 x 9-1/4	3-1/2 x 9-1/4	3-1/2 x 9-1/4
	12'	(4) 2 x 12s	3-1/2 x 9-1/4	3-1/2 x 9-1/4	3-1/2 x 9-1/4	3-1/2 x 9-1/2	3-1/2 x 11-1/4	3-1/2 x 11-1/4
	14'	3-1/2 x 9-1/4	3-1/2 x 9-1/4	3-1/2 x 11-1/4	3-1/2 x 11-1/4	3-1/2 x 11-1/4	3-1/2 x 11-1/4	3-1/2 x 11-7/8
	16'	3-1/2 x 11-1/4	3-1/2 x 11-1/4	3-1/2 x 11-1/4	3-1/2 x 11-7/8	3-1/2 x 14	3-1/2 x 14	5-1/2 x 11-7/8
	18'	3-1/2 x 11-1/4	3-1/2 x 11-7/8	3-1/2 x 14	3-1/2 x 14	3-1/2 x 14	5-1/2 x 14	5-1/2 x 14
	20'	3-1/2 x 14	3-1/2 x 14	3-1/2 x 14	3-1/2 x 16	5-1/2 x 14	5-1/2 x 14	5-1/2 x 16
	22'	3-1/2 x 14	3-1/2 x 16	3-1/2 x 16	5-1/2 x 14	5-1/2 x 16	5-1/2 x 16	5-1/2 x 16
	24'	3-1/2 x 16	3-1/2 x 16	3-1/2 x 18	5-1/2 x 16	5-1/2 x 16	5-1/2 x 18	5-1/2 x 18

(See Requirements for Use on page 7, Key and Notes on page 19, and Example on this page)

Example: Roof Ridge Beam

(See Table 16 on page 20)

Ground Snow Load** = 40 psf

(**Equivalent to a 28 psf Design Roof Snow Load)

Dead Load = 10 psf

Load Duration Factor = 1.15

Span of Supported Roof Framing = 14' + 14' = 28'

Clear Opening = 14'

Southern Pine Beam Selected: No.1 Southern Pine Lumber - (4) 2x12s or

(from Table 16) 24F-1.7E (V4) Southern Pine Glulam - 3-1/2" x 11-1/4"

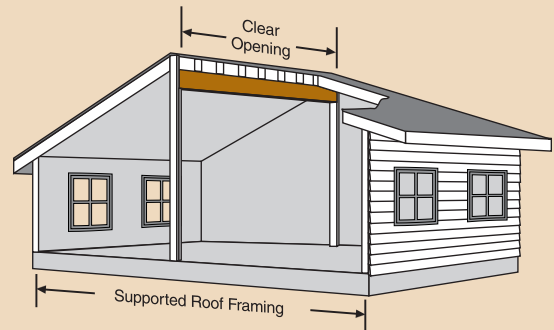

Beam size is based on the load transferred from 1/2 the span of the supported roof framing.

SOUTHERN PINE ALLOWABLE LOAD TABLES



Requirements for Use of Allowable Load Tables

1. These tables are for gravity loads only. Consult a registered design professional for wind and seismic load analysis and design.
2. All tables are based on uniformly distributed loads only. Other loads, such as concentrated or unbalanced snow loads, have not been considered and must be analyzed separately.
3. These tables are only applicable to members used under dry-service conditions where the moisture content in use is a maximum of 19% for lumber and less than 16% for glued laminated timber.
4. The compression edge of the header or beam must be laterally supported at intervals of 24" or less. In addition, lateral support must be provided at bearing points.
5. Allowable total and live plf (pounds per lineal foot) loads used to select a header or beam must be equal to or greater than the actual plf loads applied.
6. Multiple-member headers and beams must be properly connected together. See page 5 for connection guidelines.
7. These tables assume unbalanced glued laminated timber combinations used in simple-span applications. Balanced beam combinations with equal or greater design values may be substituted and used in either simple-span or continuous-span applications.
8. These tables are only applicable to members used under ordinary ranges of temperature and occasionally heated in use up to 150° F.

Example: Allowable Floor Loads

Key – for each clear opening there are three rows of values:

- TL: Maximum total load in pounds per lineal foot (plf) with deflection limited to $\ell/240$
- LL: Maximum live load in pounds per lineal foot (plf) with deflection limited to $\ell/360$
- BL: Required bearing length in inches

Steps in Sizing Headers and Beams:

1. Determine the required total load (live load + dead load) in plf.
2. Determine the required live load in plf.
3. Select a clear opening and find columns where the plf value in the TL row equals or exceeds the required total load, *and* the plf value in the LL row equals or exceeds the required live load.
4. Check required bearing lengths in the BL row.
5. Find product size options at the top of the columns meeting the total load, live load and bearing length requirements.

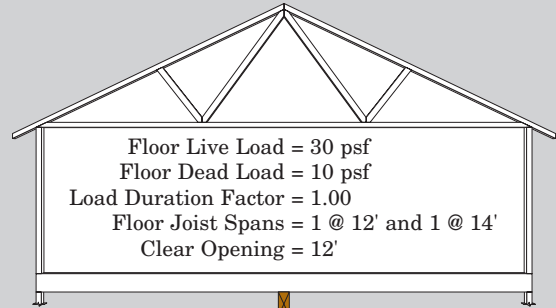

$$\text{Total Load} = (12/2 + 14/2) \times (30 + 10) \text{ psf} = 520 \text{ plf}$$

$$\text{Live Load} = (12/2 + 14/2) \times 30 \text{ psf} = 390 \text{ plf}$$

Select the 12' clear opening in Tables 21-26. Read across the TL row in each table to find columns with total loads equal to or greater than the required 520 plf. Then check the LL row in those columns to make sure the corresponding live loads are equal to or greater than the required 390 plf. Solutions include: from Table 21 for No.1 SP lumber, select a 4-ply 2x12 beam requiring a 1.5" bearing length; from Table 24 for 24F-1.7E (V4) SP glulam, select a 3-1/2x11-1/4" beam requiring a 3.0" bearing length; from Table 26 for 24F-1.8E (V3) SP glulam, select a 3-1/8x11" beam requiring a 3.0" bearing length.

Table 21 – No. 1 Southern Pine Lumber

Clear Opening		1-ply				2-ply				3-ply				4-ply			
		2 x 6	2 x 8	2 x 10	2 x 12	2 x 6	2 x 8	2 x 10	2 x 12	2 x 6	2 x 8	2 x 10	2 x 12	2 x 6	2 x 8	2 x 10	2 x 12
4'	TL	406	637	849	1150	812	1273	1697	2299	1392	2174	2887	3887	1856	2899	3849	5182
	LL	406	637	849	1150	812	1273	1697	2299	1392	2174	2887	3887	1856	2899	3849	5182
	BL	1.5	3.0	3.0	3.0	1.5	3.0	3.0	3.0	1.5	3.0	3.0	4.5	1.5	3.0	3.0	4.5
6'	TL	184	293	396	549	367	585	792	1097	632	1006	1358	1878	843	1341	1811	2504
	LL	184	293	396	549	367	585	792	1097	632	1006	1358	1878	843	1341	1811	2504
	BL	1.5	1.5	1.5	3.0	1.5	1.5	1.5	3.0	1.5	1.5	3.0	3.0	1.5	1.5	3.0	3.0
8'	TL	103	166	225	315	207	331	451	630	357	571	776	1083	475	762	1035	1444
	LL	95	166	225	315	190	331	451	630	284	571	776	1083	378	762	1035	1444
	BL	1.5	1.5	1.5	3.0	1.5	1.5	1.5	3.0	1.5	1.5	1.5	3.0	1.5	1.5	1.5	3.0
10'	TL	66	106	144	203	131	211	288	405	214	365	498	698	285	487	664	931
	LL	49	106	144	203	98	211	288	405	146	332	498	698	195	443	664	931
	BL	1.5	1.5	1.5	1.5	1.5	1.5	1.5	1.5	1.5	1.5	1.5	1.5	1.5	1.5	1.5	1.5
12'	TL	41	73	100	140	81	146	199	281	122	252	345	485	162	336	459	647
	LL	28	65	100	140	57	129	199	281	85	194	345	485	113	258	459	647
	BL	1.5	1.5	1.5	1.5	1.5	1.5	1.5	1.5	1.5	1.5	1.5	1.5	1.5	1.5	1.5	1.5
14'	TL	25	53	73	102	50	106	145	205	75	176	251	355	99	234	335	473
	LL	18	41	73	102	36	82	145	205	54	122	251	355	72	163	335	473
	BL	1.5	1.5	1.5	1.5	1.5	1.5	1.5	1.5	1.5	1.5	1.5	1.5	1.5	1.5	1.5	1.5
16'	TL	16	39	55	78	32	77	110	155	48	116	191	270	64	154	254	359
	LL	12	27	55	78	24	55	110	155	36	82	170	270	48	110	227	359
	BL	1.5	1.5	1.5	1.5	1.5	1.5	1.5	1.5	1.5	1.5	1.5	1.5	1.5	1.5	1.5	1.5
18'	TL	11	26	43	61	21	53	85	121	32	79	149	211	43	105	198	281
	LL	8	19	40	61	17	39	80	121	25	58	120	211	34	77	160	281
	BL	1.5	1.5	1.5	1.5	1.5	1.5	1.5	1.5	1.5	1.5	1.5	1.5	1.5	1.5	1.5	1.5

(See *Requirements for Use* on page 23, and *Key, Example and Notes* on this page)

Notes for Tables 21 - 26: Allowable Floor Loads (plf) - 1.00 Load Duration Factor

- Tabulated total loads (TL) and live loads (LL) represent the allowable uniformly distributed loads that a beam can support in addition to its own weight. Deflection is limited to $\ell/240$ for total load and $\ell/360$ for live load. To determine an allowable live load for a deflection limit other than $\ell/360$, multiply the LL value by the ratio of 360 divided by the desired deflection constant. The result must not exceed the corresponding TL value for the same clear opening and product.
- Tabulated bearing lengths (BL) reflect the number of 2x trimmers required at each end of the header or beam based on the corresponding plf loads (e.g., 1.5" = one trimmer, 3.0" = two trimmers, etc.). Additional checks may be required for bearing length and trimmers.
- See *Assumptions for Table Development* beginning on page 2 for details on design assumptions made to generate these tables.
- Interpolation between clear openings is permitted.
- The design span is assumed to be the clear opening plus 1/2 the required bearing length at each end.

Table 22 – No. 2 Southern Pine Lumber																	
Clear Opening		1-ply				2-ply				3-ply				4-ply			
		2 x 6	2 x 8	2 x 10	2 x 12	2 x 6	2 x 8	2 x 10	2 x 12	2 x 6	2 x 8	2 x 10	2 x 12	2 x 6	2 x 8	2 x 10	2 x 12
4'	TL	303	479	661	891	607	958	1321	1782	1043	1641	2256	3030	1390	2188	3008	4039
	LL	303	479	661	891	607	958	1321	1782	1043	1641	2256	3030	1390	2188	3008	4039
	BL	1.5	1.5	3.0	3.0	1.5	1.5	3.0	3.0	1.5	1.5	3.0	3.0	1.5	1.5	3.0	3.0
6'	TL	136	218	304	417	272	435	608	833	470	749	1045	1430	626	999	1393	1906
	LL	136	218	304	417	272	435	608	833	470	749	1045	1430	626	999	1393	1906
	BL	1.5	1.5	1.5	3.0	1.5	1.5	1.5	3.0	1.5	1.5	1.5	3.0	1.5	1.5	1.5	3.0
8'	TL	76	122	172	237	152	245	344	474	263	423	593	817	351	564	790	1089
	LL	76	122	172	237	152	245	344	474	249	423	593	817	333	564	790	1089
	BL	1.5	1.5	1.5	1.5	1.5	1.5	1.5	1.5	1.5	1.5	1.5	1.5	1.5	1.5	1.5	1.5
10'	TL	48	78	110	152	96	156	219	303	167	269	379	524	223	359	505	699
	LL	43	78	110	152	86	156	219	303	128	269	379	524	171	359	505	699
	BL	1.5	1.5	1.5	1.5	1.5	1.5	1.5	1.5	1.5	1.5	1.5	1.5	1.5	1.5	1.5	1.5
12'	TL	33	53	75	105	66	107	151	209	106	185	261	362	141	247	348	483
	LL	25	53	75	105	50	107	151	209	74	170	261	362	99	227	348	483
	BL	1.5	1.5	1.5	1.5	1.5	1.5	1.5	1.5	1.5	1.5	1.5	1.5	1.5	1.5	1.5	1.5
14'	TL	22	39	55	76	43	77	109	152	65	134	190	264	86	179	253	352
	LL	16	36	55	76	31	72	109	152	47	107	190	264	63	143	253	352
	BL	1.5	1.5	1.5	1.5	1.5	1.5	1.5	1.5	1.5	1.5	1.5	1.5	1.5	1.5	1.5	1.5
16'	TL	14	29	41	57	28	58	82	115	41	100	143	200	55	134	191	266
	LL	11	24	41	57	21	48	82	115	32	72	143	200	42	96	191	266
	BL	1.5	1.5	1.5	1.5	1.5	1.5	1.5	1.5	1.5	1.5	1.5	1.5	1.5	1.5	1.5	1.5
18'	TL	9	22	32	45	18	45	64	89	27	68	111	155	36	91	148	207
	LL	7	17	32	45	15	34	64	89	22	51	105	155	30	68	140	207
	BL	1.5	1.5	1.5	1.5	1.5	1.5	1.5	1.5	1.5	1.5	1.5	1.5	1.5	1.5	1.5	1.5

Table 23 – No. 3 Southern Pine Lumber																	
Clear Opening		1-ply				2-ply				3-ply				4-ply			
		2 x 6	2 x 8	2 x 10	2 x 12	2 x 6	2 x 8	2 x 10	2 x 12	2 x 6	2 x 8	2 x 10	2 x 12	2 x 6	2 x 8	2 x 10	2 x 12
4'	TL	176	277	403	555	352	554	805	1110	606	952	1382	1900	809	1269	1842	2533
	LL	176	277	403	555	352	554	805	1110	606	952	1382	1900	809	1269	1842	2533
	BL	1.5	1.5	1.5	1.5	1.5	1.5	1.5	1.5	1.5	1.5	1.5	3.0	1.5	1.5	1.5	3.0
6'	TL	78	124	181	253	156	247	363	506	269	427	625	871	359	569	834	1161
	LL	78	124	181	253	156	247	363	506	269	427	625	871	359	569	834	1161
	BL	1.5	1.5	1.5	1.5	1.5	1.5	1.5	1.5	1.5	1.5	1.5	1.5	1.5	1.5	1.5	1.5
8'	TL	43	69	101	142	86	138	203	284	150	238	351	491	199	318	468	655
	LL	43	69	101	142	86	138	203	284	150	238	351	491	199	318	468	655
	BL	1.5	1.5	1.5	1.5	1.5	1.5	1.5	1.5	1.5	1.5	1.5	1.5	1.5	1.5	1.5	1.5
10'	TL	27	43	64	90	54	86	128	180	94	150	222	312	125	200	296	416
	LL	27	43	64	90	54	86	128	180	94	150	222	312	125	200	296	416
	BL	1.5	1.5	1.5	1.5	1.5	1.5	1.5	1.5	1.5	1.5	1.5	1.5	1.5	1.5	1.5	1.5
12'	TL	18	29	44	61	36	58	87	123	63	102	152	214	85	136	202	285
	LL	18	29	44	61	36	58	87	123	63	102	152	214	85	136	202	285
	BL	1.5	1.5	1.5	1.5	1.5	1.5	1.5	1.5	1.5	1.5	1.5	1.5	1.5	1.5	1.5	1.5
14'	TL	13	21	31	44	26	42	62	88	45	73	109	154	60	97	145	205
	LL	13	21	31	44	26	42	62	88	44	73	109	154	58	97	145	205
	BL	1.5	1.5	1.5	1.5	1.5	1.5	1.5	1.5	1.5	1.5	1.5	1.5	1.5	1.5	1.5	1.5
16'	TL	9	15	23	33	19	31	46	66	33	54	81	115	44	72	108	154
	LL	9	15	23	33	19	31	46	66	29	54	81	115	39	72	108	154
	BL	1.5	1.5	1.5	1.5	1.5	1.5	1.5	1.5	1.5	1.5	1.5	1.5	1.5	1.5	1.5	1.5
18'	TL	7	12	18	25	14	23	35	50	25	41	62	89	33	55	83	118
	LL	7	12	18	25	14	23	35	50	21	41	62	89	27	55	83	118
	BL	1.5	1.5	1.5	1.5	1.5	1.5	1.5	1.5	1.5	1.5	1.5	1.5	1.5	1.5	1.5	1.5

(See Requirements for Use on page 23, and Key, Example and Notes on page 24)

Table 24 – 24F-1.7E (V4) Southern Pine Glued Laminated Timber

Clear Opening		3-1/2" Width								5-1/2" Width								
		Depth (in.)								Depth (in.)								
		9-1/4	9-1/2	11-1/4	11-7/8	14	16	18	19-1/4	11-1/4	11-7/8	14	16	18	19-1/4	20-5/8	22	23-3/8
6'	TL	1686	1748	2217	2401	---	---	---	---	2784	3016	3901	4906	---	---	---	---	---
	LL	1686	1748	2217	2401	---	---	---	---	2784	3016	3901	4906	---	---	---	---	---
	BL	3.0	3.0	3.0	3.0	---	---	---	---	3.0	3.0	4.5	4.5	---	---	---	---	---
8'	TL	1162	1201	1490	1600	2005	2436	2924	---	1870	2008	2517	3058	3671	4098	4613	5182	5815
	LL	1073	1160	1490	1600	2005	2436	2924	---	1870	2008	2517	3058	3671	4098	4613	5182	5815
	BL	3.0	3.0	3.0	3.0	4.5	4.5	6.0	---	3.0	3.0	3.0	4.5	4.5	4.5	6.0	6.0	7.5
10'	TL	770	811	1121	1199	1479	1768	2084	2298	1406	1504	1855	2218	2615	2883	3198	3536	3899
	LL	559	605	990	1160	1479	1768	2084	2298	1406	1504	1855	2218	2615	2883	3198	3536	3899
	BL	3.0	3.0	3.0	3.0	3.0	4.5	4.5	6.0	3.0	3.0	3.0	3.0	4.5	4.5	4.5	6.0	6.0
12'	TL	484	524	789	877	1170	1386	1617	1771	1125	1200	1467	1738	2028	2221	2444	2680	2929
	LL	328	355	582	681	1101	1386	1617	1771	918	1077	1467	1738	2028	2221	2444	2680	2929
	BL	1.5	1.5	3.0	3.0	3.0	4.5	4.5	4.5	3.0	3.0	3.0	3.0	4.5	4.5	4.5	4.5	4.5
14'	TL	305	330	546	640	893	1139	1320	1440	858	998	1213	1427	1655	1805	1976	2155	2343
	LL	209	226	371	434	702	1037	1320	1440	583	683	1111	1427	1655	1805	1976	2155	2343
	BL	1.5	1.5	1.5	3.0	3.0	4.5	4.5	4.5	1.5	3.0	3.0	3.0	3.0	4.5	4.5	4.5	4.5
16'	TL	203	220	366	430	686	891	1115	1212	575	676	1032	1210	1397	1518	1657	1801	1950
	LL	140	152	251	294	475	702	990	1205	394	462	749	1111	1397	1518	1657	1801	1950
	BL	1.5	1.5	1.5	1.5	3.0	3.0	4.5	4.5	1.5	1.5	3.0	3.0	3.0	4.5	4.5	4.5	4.5
18'	TL	140	152	256	301	493	706	890	1014	402	473	775	1049	1207	1309	1425	1545	1669
	LL	99	107	177	208	337	498	702	853	278	326	530	784	1111	1309	1425	1545	1669
	BL	1.5	1.5	1.5	1.5	3.0	3.0	4.5	4.5	1.5	1.5	3.0	3.0	3.0	3.0	4.5	4.5	4.5
20'	TL	100	109	184	218	359	535	722	822	290	342	564	840	1062	1150	1250	1352	1458
	LL	72	78	130	152	247	366	516	628	204	239	389	575	814	993	1217	1352	1458
	BL	1.5	1.5	1.5	1.5	1.5	3.0	3.0	4.5	1.5	1.5	1.5	3.0	3.0	3.0	4.5	4.5	4.5
22'	TL	73	80	136	161	268	401	570	677	214	254	421	630	896	1025	1112	1202	1293
	LL	54	59	98	115	187	277	391	475	153	180	293	435	614	749	918	1111	1293
	BL	1.5	1.5	1.5	1.5	1.5	3.0	3.0	3.0	1.5	1.5	1.5	3.0	3.0	3.0	4.5	4.5	4.5
24'	TL	---	---	103	122	204	307	439	536	162	192	321	483	689	842	993	1080	1161
	LL	---	---	75	88	144	214	303	369	118	139	227	337	476	579	710	859	1028
	BL	---	---	1.5	1.5	1.5	1.5	3.0	3.0	1.5	1.5	1.5	1.5	3.0	3.0	3.0	4.5	4.5
26'	TL	---	---	79	94	158	240	343	421	124	148	249	376	540	661	813	953	1053
	LL	---	---	59	70	114	169	239	292	93	109	179	266	376	458	561	678	811
	BL	---	---	1.5	1.5	1.5	1.5	3.0	3.0	1.5	1.5	1.5	1.5	3.0	3.0	3.0	4.5	4.5
28'	TL	---	---	61	73	124	189	273	335	---	115	196	298	429	526	649	788	919
	LL	---	---	47	56	91	136	192	235	---	88	143	213	302	369	452	546	652
	BL	---	---	1.5	1.5	1.5	1.5	1.5	3.0	---	1.5	1.5	1.5	1.5	3.0	3.0	3.0	4.5
30'	TL	---	---	---	---	99	152	219	270	---	---	156	238	345	424	524	638	766
	LL	---	---	---	---	74	111	157	191	---	---	117	174	246	301	369	446	532
	BL	---	---	---	---	1.5	1.5	1.5	3.0	---	---	1.5	1.5	1.5	3.0	3.0	3.0	3.0
32'	TL	---	---	---	---	80	123	178	220	---	---	125	193	280	346	428	522	629
	LL	---	---	---	---	61	91	130	158	---	---	96	143	204	248	305	369	441
	BL	---	---	---	---	1.5	1.5	1.5	1.5	---	---	1.5	1.5	1.5	1.5	3.0	3.0	3.0
34'	TL	---	---	---	---	64	100	146	181	---	---	101	157	230	285	353	432	521
	LL	---	---	---	---	51	76	108	132	---	---	80	120	170	207	255	308	369
	BL	---	---	---	---	1.5	1.5	1.5	1.5	---	---	1.5	1.5	1.5	1.5	1.5	3.0	3.0
36'	TL	---	---	---	---	---	82	121	150	---	---	---	129	190	236	294	360	435
	LL	---	---	---	---	---	64	91	111	---	---	---	101	143	175	215	260	311
	BL	---	---	---	---	---	1.5	1.5	1.5	---	---	---	1.5	1.5	1.5	1.5	3.0	3.0
38'	TL	---	---	---	---	---	68	101	125	---	---	---	107	158	197	246	302	366
	LL	---	---	---	---	---	55	78	95	---	---	---	86	122	149	183	222	265
	BL	---	---	---	---	---	1.5	1.5	1.5	---	---	---	1.5	1.5	1.5	1.5	1.5	3.0

(See Requirements for Use on page 23, Key and Example on page 24, and Notes on page 24 and this page)

Notes for Table 24: Allowable Floor Loads (plf) - 1.00 Load Duration Factor

- For practicality, allowable floor loads are omitted from the table when they exceed 3,000 and 6,000 pounds per lineal foot (plf) for the 3-1/2" and 5-1/2"-wide beams, respectively, and when a glued laminated timber beam span-to-depth ratio exceeds 30.
- To determine allowable floor loads for 3- and 3-1/8"-wide glued laminated timber beams, multiply tabulated total loads (TL) and live loads (LL) for 3-1/2"-wide beams by 0.857 and 0.893, respectively. Then check the required bearing length (BL).
- To determine allowable floor loads for 5- and 5-1/8"-wide glued laminated timber beams, multiply the TL and LL values for 5-1/2" wide beams by 0.909 or 0.932, respectively. Then check the required bearing length (BL).

Table 25 – 24F-1.7E (V4) Southern Pine Glued Laminated Timber

Clear Opening		3-1/8" Width									5-1/8" Width								
		Depth (in.)									Depth (in.)								
		8-1/4	9-5/8	11	12-3/8	13-3/4	15-1/8	16-1/2	17-7/8	11	12-3/8	13-3/4	15-1/8	16-1/2	17-7/8	19-1/4	20-5/8	22	23-3/8
6'	TL	1294	1589	1916	2282	2693	---	---	---	2511	2991	3529	4139	4836	5638	---	---	---	---
	LL	1294	1589	1916	2282	2693	---	---	---	2511	2991	3529	4139	4836	5638	---	---	---	---
	BL	3.0	3.0	3.0	4.5	4.5	---	---	---	3.0	3.0	3.0	4.5	4.5	6.0	---	---	---	---
8'	TL	852	1090	1292	1510	1746	2001	2279	2582	1692	1978	2287	2621	2985	3383	3818	4298	4829	5418
	LL	685	1076	1292	1510	1746	2001	2279	2582	1692	1978	2287	2621	2985	3383	3818	4298	4829	5418
	BL	1.5	3.0	3.0	3.0	4.5	4.5	4.5	6.0	3.0	3.0	3.0	3.0	4.5	4.5	4.5	6.0	6.0	7.5
10'	TL	530	743	964	1127	1290	1463	1646	1842	1274	1476	1689	1915	2156	2413	2687	2980	3295	3633
	LL	357	561	827	1127	1290	1463	1646	1842	1274	1476	1689	1915	2156	2413	2687	2980	3295	3633
	BL	1.5	3.0	3.0	3.0	3.0	4.5	4.5	4.5	3.0	3.0	3.0	3.0	3.0	4.5	4.5	4.5	6.0	6.0
12'	TL	308	486	674	848	1022	1152	1288	1431	1021	1175	1337	1507	1685	1873	2070	2278	2497	2729
	LL	209	329	486	685	933	1152	1288	1431	801	1134	1337	1507	1685	1873	2070	2278	2497	2729
	BL	1.5	1.5	3.0	3.0	3.0	4.5	4.5	4.5	3.0	3.0	3.0	3.0	3.0	4.5	4.5	4.5	4.5	4.5
14'	TL	193	307	456	626	770	927	1056	1169	748	976	1106	1241	1382	1529	1682	1841	2008	2183
	LL	133	209	310	437	595	785	1013	1169	508	719	982	1241	1382	1529	1682	1841	2008	2183
	BL	1.5	1.5	1.5	3.0	3.0	3.0	4.5	4.5	1.5	3.0	3.0	3.0	3.0	3.0	4.5	4.5	4.5	4.5
16'	TL	127	204	306	434	591	713	845	987	501	712	942	1054	1170	1290	1415	1544	1678	1817
	LL	89	141	209	296	403	532	685	866	344	486	661	877	1134	1290	1415	1544	1678	1817
	BL	1.5	1.5	1.5	3.0	3.0	3.0	3.0	4.5	1.5	3.0	3.0	3.0	3.0	3.0	4.5	4.5	4.5	4.5
18'	TL	88	142	213	304	417	554	670	784	350	499	685	909	1014	1115	1220	1328	1440	1555
	LL	63	99	148	209	285	377	486	614	243	344	468	619	801	1014	1220	1328	1440	1555
	BL	1.5	1.5	1.5	1.5	3.0	3.0	3.0	4.5	1.5	1.5	3.0	3.0	3.0	3.0	4.5	4.5	4.5	4.5
20'	TL	62	101	154	220	303	404	523	636	252	361	498	662	858	982	1072	1165	1260	1358
	LL	46	73	108	153	209	277	357	452	177	252	344	455	586	743	925	1134	1260	1358
	BL	1.5	1.5	1.5	1.5	1.5	3.0	3.0	3.0	1.5	1.5	1.5	3.0	3.0	3.0	3.0	4.5	4.5	4.5
22'	TL	---	74	113	164	226	302	393	499	186	268	371	496	644	818	955	1036	1120	1205
	LL	---	55	81	116	158	209	271	342	134	190	259	344	444	561	698	856	1035	1205
	BL	---	1.5	1.5	1.5	1.5	1.5	3.0	3.0	1.5	1.5	1.5	1.5	3.0	3.0	3.0	4.5	4.5	4.5
24'	TL	---	---	86	124	172	231	301	384	140	204	283	379	494	629	785	929	1007	1082
	LL	---	---	63	89	122	162	209	265	103	146	200	266	344	435	540	661	801	958
	BL	---	---	1.5	1.5	1.5	1.5	3.0	3.0	1.5	1.5	1.5	1.5	3.0	3.0	3.0	3.0	4.5	4.5
26'	TL	---	---	66	96	134	180	235	300	107	157	219	295	385	492	616	758	892	981
	LL	---	---	49	70	96	128	165	209	81	115	158	210	271	344	427	523	632	756
	BL	---	---	1.5	1.5	1.5	1.5	1.5	3.0	1.5	1.5	1.5	1.5	1.5	3.0	3.0	3.0	4.5	4.5
28'	TL	---	---	---	75	105	142	186	238	---	123	172	233	305	391	490	605	734	860
	LL	---	---	---	56	77	103	133	168	---	92	127	168	218	276	344	421	508	607
	BL	---	---	---	1.5	1.5	1.5	1.5	1.5	---	1.5	1.5	1.5	1.5	1.5	3.0	3.0	3.0	4.5
30'	TL	---	---	---	59	83	113	149	192	---	97	137	186	245	314	395	489	595	714
	LL	---	---	---	46	63	83	108	137	---	75	103	137	177	225	280	344	415	496
	BL	---	---	---	1.5	1.5	1.5	1.5	1.5	---	1.5	1.5	1.5	1.5	1.5	3.0	3.0	3.0	3.0
32'	TL	---	---	---	---	67	91	121	156	---	---	110	150	198	256	322	399	487	586
	LL	---	---	---	---	52	69	89	113	---	---	85	113	146	186	231	284	344	411
	BL	---	---	---	---	1.5	1.5	1.5	1.5	---	---	1.5	1.5	1.5	1.5	1.5	3.0	3.0	3.0
34'	TL	---	---	---	---	54	74	99	128	---	---	89	122	162	210	265	329	402	485
	LL	---	---	---	---	43	57	75	95	---	---	71	94	122	155	193	237	287	344
	BL	---	---	---	---	1.5	1.5	1.5	1.5	---	---	1.5	1.5	1.5	1.5	1.5	1.5	3.0	3.0
36'	TL	---	---	---	---	---	61	81	106	---	---	---	100	133	173	220	274	335	405
	LL	---	---	---	---	---	48	63	80	---	---	---	79	103	131	163	200	243	290
	BL	---	---	---	---	---	1.5	1.5	1.5	---	---	---	1.5	1.5	1.5	1.5	1.5	3.0	3.0
38'	TL	---	---	---	---	---	---	67	88	---	---	---	---	110	144	183	229	281	341
	LL	---	---	---	---	---	---	53	68	---	---	---	---	88	111	139	171	207	247
	BL	---	---	---	---	---	---	1.5	1.5	---	---	---	---	1.5	1.5	1.5	1.5	1.5	3.0

(See Requirements for Use on page 23, Key and Example on page 24, and Notes on page 24 and this page)

Notes for Table 25: Allowable Floor Loads (plf) - 1.00 Load Duration Factor

- For practicality, allowable floor loads are omitted from the table when they exceed 3,000 and 6,000 pounds per lineal foot (plf) for the 3-1/8" and 5-1/8"-wide beams, respectively, and when a glued laminated timber beam span-to-depth ratio exceeds 30.
- To determine allowable floor loads for 3- and 3-1/2"-wide glued laminated timber beams, multiply tabulated total loads (TL) and live loads (LL) for 3-1/8"-wide beams by 0.96 and 1.12, respectively. Then check the required bearing length (BL).
- To determine allowable floor loads for 5- and 5-1/2"-wide glued laminated timber beams, multiply the TL and LL values for 5-1/8" wide beams by 0.976 or 1.073, respectively. Then check the required bearing length (BL).

Table 26 – 24F-1.8E (V3) Southern Pine Glued Laminated Timber

Clear Opening		3-1/8" Width									5-1/8" Width								
		Depth (in.)									Depth (in.)								
		8-1/4	9-5/8	11	12-3/8	13-3/4	15-1/8	16-1/2	17-7/8	11	12-3/8	13-3/4	15-1/8	16-1/2	17-7/8	19-1/4	20-5/8	22	23-3/8
6'	TL	1481	1975	2531	---	---	---	---	---	4128	5081	---	---	---	---	---	---	---	---
	LL	1481	1975	2531	---	---	---	---	---	4128	5081	---	---	---	---	---	---	---	---
	BL	3.0	3.0	4.5	---	---	---	---	---	4.5	4.5	---	---	---	---	---	---	---	---
8'	TL	852	1147	1479	1844	2238	2656	---	---	2425	3024	3670	4357	5076	5820	---	---	---	---
	LL	726	1132	1479	1844	2238	2656	---	---	2425	3024	3670	4357	5076	5820	---	---	---	---
	BL	1.5	3.0	3.0	4.5	4.5	6.0	---	---	3.0	4.5	4.5	6.0	6.0	7.5	---	---	---	---
10'	TL	549	743	963	1208	1477	1766	2074	2400	1580	1982	2422	2896	3402	3936	4493	5071	5664	---
	LL	378	594	875	1208	1477	1766	2074	2400	1435	1982	2422	2896	3402	3936	4493	5071	5664	---
	BL	1.5	3.0	3.0	3.0	4.5	4.5	6.0	6.0	3.0	3.0	4.5	4.5	6.0	6.0	7.5	7.5	9.0	---
12'	TL	326	515	674	848	1041	1250	1474	1714	1105	1391	1707	2049	2418	2811	3226	3661	4106	4561
	LL	222	348	515	726	984	1250	1474	1714	844	1190	1614	2049	2418	2811	3226	3661	4106	4561
	BL	1.5	1.5	3.0	3.0	3.0	4.5	4.5	6.0	3.0	3.0	3.0	4.5	4.5	6.0	6.0	7.5	7.5	9.0
14'	TL	204	325	483	626	770	927	1097	1279	792	1027	1263	1520	1799	2097	2407	2732	3072	3426
	LL	140	222	328	463	630	830	1067	1279	537	759	1033	1362	1750	2097	2407	2732	3072	3426
	BL	1.5	1.5	1.5	3.0	3.0	3.0	4.5	4.5	1.5	3.0	3.0	3.0	4.5	4.5	6.0	6.0	6.0	7.5
16'	TL	135	216	324	460	591	713	845	987	531	754	969	1169	1383	1609	1850	2105	2373	2653
	LL	94	149	222	313	426	563	726	915	363	513	699	924	1190	1501	1850	2105	2373	2653
	BL	1.5	1.5	1.5	3.0	3.0	3.0	3.0	4.5	1.5	3.0	3.0	3.0	3.0	4.5	4.5	6.0	6.0	6.0
18'	TL	93	150	226	323	442	564	670	784	371	529	725	922	1089	1270	1462	1666	1881	2107
	LL	67	105	156	222	302	399	515	650	257	363	495	655	845	1067	1324	1616	1881	2107
	BL	1.5	1.5	1.5	1.5	3.0	3.0	3.0	4.5	1.5	1.5	3.0	3.0	3.0	4.5	4.5	4.5	6.0	6.0
20'	TL	66	108	163	234	322	428	543	636	267	383	527	701	878	1025	1181	1348	1523	1709
	LL	49	77	114	162	222	293	378	478	188	266	363	481	620	785	975	1192	1437	1709
	BL	1.5	1.5	1.5	1.5	1.5	3.0	3.0	3.0	1.5	1.5	1.5	3.0	3.0	3.0	4.5	4.5	4.5	6.0
22'	TL	---	79	121	174	240	320	416	525	198	285	394	525	682	842	972	1110	1256	1410
	LL	---	58	86	122	167	222	286	362	141	201	274	363	469	593	738	903	1090	1300
	BL	---	1.5	1.5	1.5	1.5	3.0	3.0	3.0	1.5	1.5	1.5	3.0	3.0	3.0	3.0	4.5	4.5	4.5
24'	TL	---	---	91	132	183	245	319	406	149	216	300	402	524	666	812	928	1052	1182
	LL	---	---	67	94	129	171	222	280	109	155	212	281	363	460	571	700	846	1010
	BL	---	---	1.5	1.5	1.5	1.5	3.0	3.0	1.5	1.5	1.5	1.5	3.0	3.0	3.0	3.0	4.5	4.5
26'	TL	---	---	70	102	142	191	249	318	115	167	233	313	409	522	653	787	892	1002
	LL	---	---	52	74	102	135	175	222	86	122	167	222	287	363	452	553	669	799
	BL	---	---	1.5	1.5	1.5	1.5	1.5	3.0	1.5	1.5	1.5	1.5	1.5	3.0	3.0	3.0	4.5	4.5
28'	TL	---	---	---	80	112	151	198	253	---	131	183	247	324	415	520	641	764	860
	LL	---	---	---	60	82	108	140	178	---	98	134	178	230	292	363	445	538	643
	BL	---	---	---	1.5	1.5	1.5	1.5	3.0	---	1.5	1.5	1.5	1.5	3.0	3.0	3.0	3.0	4.5
30'	TL	---	---	---	63	89	121	159	204	---	103	146	198	260	334	420	518	630	745
	LL	---	---	---	49	67	88	114	145	---	80	109	145	188	238	296	363	439	525
	BL	---	---	---	1.5	1.5	1.5	1.5	1.5	---	1.5	1.5	1.5	1.5	1.5	3.0	3.0	3.0	3.0
32'	TL	---	---	---	---	71	97	129	166	---	---	117	160	211	272	342	424	517	621
	LL	---	---	---	---	55	73	94	120	---	---	90	120	155	197	245	300	363	434
	BL	---	---	---	---	1.5	1.5	1.5	1.5	---	---	1.5	1.5	1.5	1.5	1.5	3.0	3.0	3.0
34'	TL	---	---	---	---	58	79	105	136	---	---	95	130	173	223	282	350	427	515
	LL	---	---	---	---	46	61	79	100	---	---	75	100	129	164	205	251	304	363
	BL	---	---	---	---	1.5	1.5	1.5	1.5	---	---	1.5	1.5	1.5	1.5	1.5	3.0	3.0	3.0
36'	TL	---	---	---	---	65	87	113	---	---	---	107	142	185	234	291	356	430	---
	LL	---	---	---	---	51	67	84	---	---	---	84	109	138	173	212	257	307	---
	BL	---	---	---	---	1.5	1.5	1.5	---	---	---	1.5	1.5	1.5	1.5	1.5	3.0	3.0	---
38'	TL	---	---	---	---	---	72	94	---	---	---	---	118	154	196	244	299	362	---
	LL	---	---	---	---	---	57	72	---	---	---	---	93	118	147	180	219	262	---
	BL	---	---	---	---	---	1.5	1.5	---	---	---	---	1.5	1.5	1.5	1.5	3.0	3.0	---

(See Requirements for Use on page 23, Key and Example on page 24, and Notes on page 24 and this page)

Notes for Table 26: Allowable Floor Loads (plf) - 1.00 Load Duration Factor

- For practicality, allowable floor loads are omitted from the table when they exceed 3,000 and 6,000 pounds per lineal foot (plf) for the 3-1/8" and 5-1/8"-wide beams, respectively, and when a glued laminated timber beam span-to-depth ratio exceeds 30.
- To determine allowable floor loads for 3- and 3-1/2"-wide glued laminated timber beams, multiply tabulated total loads (TL) and live loads (LL) for 3-1/8"-wide beams by 0.96 and 1.12, respectively. Then check the required bearing length (BL).
- To determine allowable floor loads for 5- and 5-1/2"-wide glued laminated timber beams, multiply the TL and LL values for 5-1/8" wide beams by 0.976 and 1.073, respectively. Then check the required bearing length (BL).

Example: Allowable Roof Loads

Key – for each clear opening there are three rows of values:

- TL: Maximum total load in pounds per lineal foot (plf) with deflection limited to $\ell/180$
- LL: Maximum live load in pounds per lineal foot (plf) with deflection limited to $\ell/240$
- BL: Required bearing length in inches

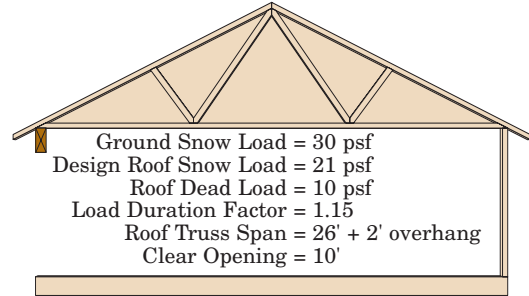

Total Load = $(26/2 + 2') \times (21 + 10) \text{ psf} = 465 \text{ plf}$
 Live Load = $(26/2 + 2') \times 21 \text{ psf} = 315 \text{ plf}$

Steps in Sizing Headers and Beams:

1. Determine the required total load (live load + dead load) in plf.
2. Determine the required live load in plf.
3. Select a clear opening and find columns where the plf value in the TL row equals or exceeds the required total load, *and* the plf value in the LL row equals or exceeds the required live load.
4. Check required bearing lengths in the BL row.
5. Find product size options at the top of the columns meeting the total load, live load and bearing length requirements.

Select the 10' clear opening in Tables 27-32. Read across the TL row in each table to find columns with total loads equal to or greater than the required 465 plf. Then check the LL row in those columns to make sure the corresponding live loads are equal to or greater than the required 315 plf. Solutions include: from Table 27 for No.1 SP lumber, select (2) 2x12s, (3) 2x10s or (4) 2x8s; from Table 28 for No.2 SP lumber, select (3) 2x12s or (4) 2x10s; from Table 29 for No.3 SP lumber, select (4) 2x12s; from Table 30 for 24F-1.7E (V4) SP glulam, select a 3-1/2x9-1/4" beam; from Table 32 for 24F-1.8E (V3) SP glulam, select a 3-1/8x8-1/4" beam. All of the lumber solutions and the 24F-1.8E glulam solution require a 1.5" bearing length, while the 24F-1.7E glulam solution requires a 3.0" bearing length.

Table 27 – No. 1 Southern Pine Lumber

Clear Opening		1-ply				2-ply				3-ply				4-ply			
		2 x 6	2 x 8	2 x 10	2 x 12	2 x 6	2 x 8	2 x 10	2 x 12	2 x 6	2 x 8	2 x 10	2 x 12	2 x 6	2 x 8	2 x 10	2 x 12
4'	TL	464	725	962	1296	928	1450	1925	2591	1590	2472	3266	4366	2120	3296	4355	5821
	LL	464	725	962	1296	928	1450	1925	2591	1590	2472	3266	4366	2120	3296	4355	5821
	BL	1.5	3.0	3.0	4.5	1.5	3.0	3.0	4.5	1.5	3.0	3.0	4.5	1.5	3.0	3.0	4.5
6'	TL	211	335	453	626	422	671	906	1252	726	1152	1552	2139	968	1536	2070	2852
	LL	211	335	453	626	422	671	906	1252	726	1152	1552	2139	968	1536	2070	2852
	BL	1.5	1.5	3.0	3.0	1.5	1.5	3.0	3.0	1.5	1.5	3.0	3.0	1.5	1.5	3.0	3.0
8'	TL	119	190	259	361	238	381	517	722	410	656	890	1240	547	875	1187	1654
	LL	119	190	259	361	238	381	517	722	410	656	890	1240	547	875	1187	1654
	BL	1.5	1.5	1.5	3.0	1.5	1.5	1.5	3.0	1.5	1.5	1.5	3.0	1.5	1.5	1.5	3.0
10'	TL	76	122	166	233	151	244	332	466	262	421	573	802	349	561	764	1069
	LL	73	122	166	233	146	244	332	466	219	421	573	802	292	561	764	1069
	BL	1.5	1.5	1.5	1.5	1.5	1.5	1.5	1.5	1.5	1.5	1.5	3.0	1.5	1.5	1.5	3.0
12'	TL	52	84	115	162	104	168	230	323	164	291	397	558	218	388	529	744
	LL	42	84	115	162	85	168	230	323	127	290	397	558	170	386	529	744
	BL	1.5	1.5	1.5	1.5	1.5	1.5	1.5	1.5	1.5	1.5	1.5	1.5	1.5	1.5	1.5	1.5
14'	TL	34	61	84	118	68	123	168	236	101	212	290	409	135	283	387	545
	LL	27	61	84	118	54	122	168	236	80	183	290	409	107	244	387	545
	BL	1.5	1.5	1.5	1.5	1.5	1.5	1.5	1.5	1.5	1.5	1.5	1.5	1.5	1.5	1.5	1.5
16'	TL	22	46	64	90	44	93	127	180	66	156	220	311	88	208	294	415
	LL	18	41	64	90	36	82	127	180	54	123	220	311	72	164	294	415
	BL	1.5	1.5	1.5	1.5	1.5	1.5	1.5	1.5	1.5	1.5	1.5	1.5	1.5	1.5	1.5	1.5
18'	TL	15	36	50	70	30	72	99	141	45	108	172	244	60	144	230	325
	LL	13	29	50	70	25	58	99	141	38	87	172	244	51	116	230	325
	BL	1.5	1.5	1.5	1.5	1.5	1.5	1.5	1.5	1.5	1.5	1.5	1.5	1.5	1.5	1.5	1.5

(See *Requirements for Use* on page 23, and *Key, Example and Notes* on this page)

Notes for Tables 27 - 32: Allowable Roof Loads (plf) - 1.15 Load Duration Factor

- Tabulated total loads (TL) and live loads (LL) represent the allowable uniformly distributed loads that a beam can support in addition to its own weight. Deflection is limited to $\ell/180$ for total load and $\ell/240$ for live load. To determine an allowable live load for a deflection limit other than $\ell/240$, multiply the LL value by the ratio of 240 divided by the desired deflection constant. The result must not exceed the corresponding TL value for the same clear opening and product.
- Tabulated bearing lengths (BL) reflect the number of 2x trimmers required at each end of the header or beam based on the corresponding plf loads (e.g., 1.5" = one trimmer, 3.0" = two trimmers, etc.). Additional checks may be required for bearing length and trimmers.
- See *Assumptions for Table Development* beginning on page 2 for details on design assumptions made to generate these tables.
- Interpolation between clear openings is permitted.
- The design span is assumed to be the clear opening plus 1/2 the required bearing length at each end.

Table 28 – No. 2 Southern Pine Lumber

Clear Opening		1-ply				2-ply				3-ply				4-ply			
		2 x 6	2 x 8	2 x 10	2 x 12	2 x 6	2 x 8	2 x 10	2 x 12	2 x 6	2 x 8	2 x 10	2 x 12	2 x 6	2 x 8	2 x 10	2 x 12
4'	TL	348	547	752	1010	695	1094	1504	2020	1194	1872	2563	3425	1591	2495	3418	4566
	LL	348	547	752	1010	695	1094	1504	2020	1194	1872	2563	3425	1591	2495	3418	4566
	BL	1.5	1.5	3.0	3.0	1.5	1.5	3.0	3.0	1.5	3.0	3.0	3.0	1.5	3.0	3.0	3.0
6'	TL	157	250	348	477	313	499	696	953	540	859	1196	1633	720	1146	1595	2178
	LL	157	250	348	477	313	499	696	953	540	859	1196	1633	720	1146	1595	2178
	BL	1.5	1.5	1.5	3.0	1.5	1.5	1.5	3.0	1.5	1.5	1.5	3.0	1.5	1.5	1.5	3.0
8'	TL	88	141	198	272	176	282	395	545	303	486	681	937	405	648	908	1250
	LL	88	141	198	272	176	282	395	545	303	486	681	937	405	648	908	1250
	BL	1.5	1.5	1.5	1.5	1.5	1.5	1.5	1.5	1.5	1.5	1.5	3.0	1.5	1.5	1.5	3.0
10'	TL	56	90	126	175	111	179	252	349	193	310	436	603	257	414	581	804
	LL	56	90	126	175	111	179	252	349	192	310	436	603	256	414	581	804
	BL	1.5	1.5	1.5	1.5	1.5	1.5	1.5	1.5	1.5	1.5	1.5	1.5	1.5	1.5	1.5	1.5
12'	TL	38	62	87	121	76	123	174	242	132	214	301	418	177	285	402	557
	LL	37	62	87	121	74	123	174	242	112	214	301	418	149	285	402	557
	BL	1.5	1.5	1.5	1.5	1.5	1.5	1.5	1.5	1.5	1.5	1.5	1.5	1.5	1.5	1.5	1.5
14'	TL	28	45	63	88	55	89	126	176	88	155	219	305	117	207	292	406
	LL	23	45	63	88	47	89	126	176	70	155	219	305	94	207	292	406
	BL	1.5	1.5	1.5	1.5	1.5	1.5	1.5	1.5	1.5	1.5	1.5	1.5	1.5	1.5	1.5	1.5
16'	TL	19	34	48	67	38	67	95	133	57	117	166	231	76	156	221	308
	LL	16	34	48	67	31	67	95	133	47	108	166	231	63	144	221	308
	BL	1.5	1.5	1.5	1.5	1.5	1.5	1.5	1.5	1.5	1.5	1.5	1.5	1.5	1.5	1.5	1.5
18'	TL	13	26	37	52	26	52	74	104	38	91	129	180	51	122	172	241
	LL	11	25	37	52	22	51	74	104	33	76	129	180	44	101	172	241
	BL	1.5	1.5	1.5	1.5	1.5	1.5	1.5	1.5	1.5	1.5	1.5	1.5	1.5	1.5	1.5	1.5

Table 29 – No. 3 Southern Pine Lumber

Clear Opening		1-ply				2-ply				3-ply				4-ply			
		2 x 6	2 x 8	2 x 10	2 x 12	2 x 6	2 x 8	2 x 10	2 x 12	2 x 6	2 x 8	2 x 10	2 x 12	2 x 6	2 x 8	2 x 10	2 x 12
4'	TL	202	317	461	633	404	635	921	1267	696	1090	1579	2164	928	1454	2105	2885
	LL	202	317	461	633	404	635	921	1267	696	1090	1579	2164	928	1454	2105	2885
	BL	1.5	1.5	1.5	3.0	1.5	1.5	1.5	3.0	1.5	1.5	1.5	3.0	1.5	1.5	1.5	3.0
6'	TL	90	142	208	290	180	284	417	580	310	491	718	999	414	654	958	1331
	LL	90	142	208	290	180	284	417	580	310	491	718	999	414	654	958	1331
	BL	1.5	1.5	1.5	1.5	1.5	1.5	1.5	1.5	1.5	1.5	1.5	1.5	1.5	1.5	1.5	1.5
8'	TL	50	79	117	164	100	159	234	327	173	275	404	565	230	366	539	753
	LL	50	79	117	164	100	159	234	327	173	275	404	565	230	366	539	753
	BL	1.5	1.5	1.5	1.5	1.5	1.5	1.5	1.5	1.5	1.5	1.5	1.5	1.5	1.5	1.5	1.5
10'	TL	31	50	74	104	63	100	148	208	109	174	256	360	145	231	342	480
	LL	31	50	74	104	63	100	148	208	109	174	256	360	145	231	342	480
	BL	1.5	1.5	1.5	1.5	1.5	1.5	1.5	1.5	1.5	1.5	1.5	1.5	1.5	1.5	1.5	1.5
12'	TL	21	34	51	71	42	68	101	142	74	118	176	247	98	158	234	330
	LL	21	34	51	71	42	68	101	142	74	118	176	247	98	158	234	330
	BL	1.5	1.5	1.5	1.5	1.5	1.5	1.5	1.5	1.5	1.5	1.5	1.5	1.5	1.5	1.5	1.5
14'	TL	15	24	36	51	30	49	73	103	53	85	127	179	70	113	169	238
	LL	15	24	36	51	30	49	73	103	53	85	127	179	70	113	169	238
	BL	1.5	1.5	1.5	1.5	1.5	1.5	1.5	1.5	1.5	1.5	1.5	1.5	1.5	1.5	1.5	1.5
16'	TL	11	18	27	38	22	36	54	77	39	63	95	134	52	84	126	179
	LL	11	18	27	38	22	36	54	77	39	63	95	134	52	84	126	179
	BL	1.5	1.5	1.5	1.5	1.5	1.5	1.5	1.5	1.5	1.5	1.5	1.5	1.5	1.5	1.5	1.5
18'	TL	8	14	21	30	17	27	41	59	30	48	73	104	39	65	97	138
	LL	8	14	21	30	17	27	41	59	30	48	73	104	39	65	97	138
	BL	1.5	1.5	1.5	1.5	1.5	1.5	1.5	1.5	1.5	1.5	1.5	1.5	1.5	1.5	1.5	1.5

(See Requirements for Use on page 23, and Key, Example and Notes on page 29)

Table 30 – 24F-1.7E (V4) Southern Pine Glued Laminated Timber

Clear Opening		3-1/2" Width								5-1/2" Width								
		Depth (in.)								Depth (in.)								
		9-1/4	9-1/2	11-1/4	11-7/8	14	16	18	19-1/4	11-1/4	11-7/8	14	16	18	19-1/4	20-5/8	22	23-3/8
6'	TL	1940	2012	2551	2763	---	---	---	---	3204	3470	4489	5645	---	---	---	---	---
	LL	1940	2012	2551	2763	---	---	---	---	3204	3470	4489	5645	---	---	---	---	---
	BL	3.0	3.0	4.5	4.5	---	---	---	---	3.0	3.0	4.5	4.5	---	---	---	---	---
8'	TL	1337	1382	1715	1842	2308	2803	---	---	2153	2312	2898	3520	4225	4717	5309	5964	---
	LL	1337	1382	1715	1842	2308	2803	---	---	2153	2312	2898	3520	4225	4717	5309	5964	---
	BL	3.0	3.0	3.0	3.0	4.5	6.0	---	---	3.0	3.0	3.0	4.5	4.5	6.0	6.0	7.5	---
10'	TL	883	930	1290	1380	1703	2035	2399	2645	1619	1732	2137	2554	3011	3320	3682	4071	4489
	LL	834	901	1290	1380	1703	2035	2399	2645	1619	1732	2137	2554	3011	3320	3682	4071	4489
	BL	3.0	3.0	3.0	3.0	4.5	6.0	6.0	6.0	3.0	3.0	3.0	4.5	4.5	4.5	6.0	6.0	6.0
12'	TL	617	650	905	1005	1348	1596	1862	2039	1296	1383	1691	2002	2336	2558	2815	3086	3373
	LL	489	529	867	1005	1348	1596	1862	2039	1296	1383	1691	2002	2336	2558	2815	3086	3373
	BL	1.5	3.0	3.0	3.0	4.5	4.5	4.5	6.0	3.0	3.0	3.0	4.5	4.5	4.5	4.5	6.0	6.0
14'	TL	407	441	668	743	1024	1312	1521	1658	1049	1150	1397	1645	1907	2079	2277	2483	2699
	LL	311	337	553	648	1024	1312	1521	1658	869	1019	1397	1645	1907	2079	2277	2483	2699
	BL	1.5	1.5	3.0	3.0	3.0	4.5	4.5	6.0	3.0	3.0	3.0	3.0	4.5	4.5	4.5	4.5	6.0
16'	TL	272	295	488	570	788	1022	1285	1396	767	895	1190	1395	1610	1750	1910	2076	2248
	LL	210	227	374	438	709	1022	1285	1396	587	688	1117	1395	1610	1750	1910	2076	2248
	BL	1.5	1.5	3.0	3.0	3.0	4.5	4.5	4.5	3.0	3.0	3.0	3.0	4.5	4.5	4.5	4.5	6.0
18'	TL	189	205	343	403	623	811	1021	1163	538	633	976	1210	1392	1510	1644	1782	1924
	LL	148	160	264	310	502	743	1021	1163	415	487	790	1171	1392	1510	1644	1782	1924
	BL	1.5	1.5	1.5	1.5	3.0	3.0	4.5	4.5	1.5	1.5	3.0	3.0	4.5	4.5	4.5	4.5	4.5
20'	TL	136	148	248	293	479	658	829	944	390	460	753	1018	1225	1327	1442	1560	1681
	LL	108	117	194	227	369	546	770	936	304	357	580	858	1214	1327	1442	1560	1681
	BL	1.5	1.5	1.5	1.5	3.0	3.0	4.5	4.5	1.5	1.5	3.0	3.0	4.5	4.5	4.5	4.5	4.5
22'	TL	100	109	185	218	359	536	684	778	290	343	565	836	1050	1183	1283	1386	1492
	LL	81	88	146	171	279	412	583	709	229	269	438	648	917	1117	1283	1386	1492
	BL	1.5	1.5	1.5	1.5	3.0	3.0	3.0	4.5	1.5	1.5	3.0	3.0	3.0	4.5	4.5	4.5	4.5
24'	TL	---	---	140	166	275	412	572	651	220	261	432	648	878	1000	1143	1247	1340
	LL	---	---	113	132	216	320	452	550	177	208	339	502	710	865	1059	1247	1340
	BL	---	---	1.5	1.5	1.5	3.0	3.0	4.5	1.5	1.5	1.5	3.0	3.0	3.0	4.5	4.5	4.5
26'	TL	---	---	108	129	214	323	460	552	170	202	337	507	723	847	969	1097	1216
	LL	---	---	89	104	170	253	357	435	139	164	267	397	561	684	838	1012	1211
	BL	---	---	1.5	1.5	1.5	3.0	3.0	3.0	1.5	1.5	1.5	3.0	3.0	3.0	4.5	4.5	4.5
28'	TL	---	---	85	101	170	256	367	450	---	159	267	403	577	706	831	942	1059
	LL	---	---	71	84	137	203	287	350	---	131	215	319	451	550	674	815	973
	BL	---	---	1.5	1.5	1.5	1.5	3.0	3.0	---	1.5	1.5	1.5	3.0	3.0	3.0	4.5	4.5
30'	TL	---	---	---	---	136	206	297	364	---	---	214	324	466	572	704	816	918
	LL	---	---	---	---	111	165	234	286	---	---	175	260	368	449	550	665	795
	BL	---	---	---	---	1.5	1.5	3.0	3.0	---	---	1.5	1.5	3.0	3.0	3.0	4.5	4.5
32'	TL	---	---	---	---	110	168	242	298	---	---	173	264	381	468	578	703	802
	LL	---	---	---	---	92	137	194	236	---	---	144	215	304	371	455	550	657
	BL	---	---	---	---	1.5	1.5	3.0	3.0	---	---	1.5	1.5	3.0	3.0	3.0	3.0	4.5
34'	TL	---	---	---	---	90	138	200	246	---	---	141	217	314	387	479	583	701
	LL	---	---	---	---	77	114	162	197	---	---	120	179	254	310	380	460	550
	BL	---	---	---	---	1.5	1.5	1.5	3.0	---	---	1.5	1.5	1.5	3.0	3.0	3.0	3.0
36'	TL	---	---	---	---	---	114	166	205	---	---	---	179	261	322	400	488	587
	LL	---	---	---	---	---	96	137	167	---	---	---	151	215	262	321	389	465
	BL	---	---	---	---	---	1.5	1.5	1.5	---	---	---	1.5	1.5	1.5	3.0	3.0	3.0
38'	TL	---	---	---	---	---	95	139	172	---	---	---	149	219	271	336	411	496
	LL	---	---	---	---	---	82	116	142	---	---	---	129	183	223	274	331	396
	BL	---	---	---	---	---	1.5	1.5	1.5	---	---	---	1.5	1.5	1.5	3.0	3.0	3.0

(See Requirements for Use on page 23, Key and Example on page 29, and Notes on page 29 and this page)

Notes for Table 30: Allowable Roof Loads (plf) - 1.15 Load Duration Factor

- For practicality, allowable roof loads are omitted from the table when they exceed 3,000 and 6,000 pounds per lineal foot (plf) for the 3-1/2" and 5-1/2"-wide beams, respectively, and when a glued laminated timber's span-to-depth ratio exceeds 30.
- To determine allowable roof loads for 3- and 3-1/8"-wide glued laminated timber beams, multiply tabulated total loads (TL) and live loads (LL) for 3-1/2"-wide beams by 0.857 and 0.893, respectively. Then check the required bearing length (BL).
- To determine allowable roof loads for 5- and 5-1/8"-wide glued laminated timber beams, multiply the TL and LL values for 5-1/2" wide beams by 0.909 or 0.932, respectively. Then check the required bearing length (BL).

Table 31 – 24F-1.7E (V4) Southern Pine Glued Laminated Timber																			
Clear Opening		3-1/8" Width								5-1/8" Width									
		Depth (in.)								Depth (in.)									
		8-1/4	9-5/8	11	12-3/8	13-3/4	15-1/8	16-1/2	17-7/8	11	12-3/8	13-3/4	15-1/8	16-1/2	17-7/8	19-1/4	20-5/8	22	23-3/8
6'	TL	1489	1828	2205	2626	---	---	---	---	2890	3442	4062	4763	5564	---	---	---	---	---
	LL	1489	1828	2205	2626	---	---	---	---	2890	3442	4062	4763	5564	---	---	---	---	---
	BL	3.0	3.0	3.0	4.5	---	---	---	---	3.0	3.0	4.5	4.5	6.0	---	---	---	---	---
8'	TL	976	1254	1487	1738	2009	2303	2622	2971	1948	2277	2632	3017	3436	3894	4395	4947	5557	---
	LL	976	1254	1487	1738	2009	2303	2622	2971	1948	2277	2632	3017	3436	3894	4395	4947	5557	---
	BL	3.0	3.0	3.0	4.5	4.5	4.5	6.0	6.0	3.0	3.0	3.0	4.5	4.5	4.5	6.0	6.0	7.5	---
10'	TL	631	852	1104	1298	1485	1684	1895	2121	1468	1699	1945	2205	2483	2778	3093	3431	3793	4183
	LL	533	836	1104	1298	1485	1684	1895	2121	1468	1699	1945	2205	2483	2778	3093	3431	3793	4183
	BL	1.5	3.0	3.0	3.0	4.5	4.5	4.5	6.0	3.0	3.0	3.0	4.5	4.5	4.5	4.5	6.0	6.0	6.0
12'	TL	410	595	773	972	1177	1326	1483	1648	1176	1354	1540	1736	1941	2157	2384	2623	2876	3143
	LL	312	491	725	972	1177	1326	1483	1648	1176	1354	1540	1736	1941	2157	2384	2623	2876	3143
	BL	1.5	3.0	3.0	3.0	4.5	4.5	4.5	4.5	3.0	3.0	3.0	3.0	4.5	4.5	4.5	4.5	6.0	6.0
14'	TL	258	409	570	719	883	1063	1217	1346	935	1125	1274	1430	1592	1761	1938	2122	2314	2515
	LL	198	312	462	652	883	1063	1217	1346	758	1073	1274	1430	1592	1761	1938	2122	2314	2515
	BL	1.5	1.5	3.0	3.0	3.0	4.5	4.5	4.5	3.0	3.0	3.0	3.0	4.5	4.5	4.5	4.5	4.5	6.0
16'	TL	172	274	408	552	679	818	969	1133	669	905	1086	1215	1349	1487	1631	1780	1934	2094
	LL	134	211	312	441	601	793	969	1133	512	724	987	1215	1349	1487	1631	1780	1934	2094
	BL	1.5	1.5	1.5	3.0	3.0	3.0	4.5	4.5	1.5	3.0	3.0	3.0	3.0	4.5	4.5	4.5	4.5	6.0
18'	TL	119	191	286	407	537	648	769	899	469	667	881	1055	1169	1286	1407	1532	1660	1793
	LL	94	149	221	312	425	563	725	899	362	512	698	924	1169	1286	1407	1532	1660	1793
	BL	1.5	1.5	1.5	3.0	3.0	3.0	4.5	4.5	1.5	3.0	3.0	3.0	3.0	4.5	4.5	4.5	4.5	4.5
20'	TL	85	137	207	296	406	525	624	730	339	485	665	854	1010	1132	1236	1343	1453	1567
	LL	69	109	162	229	312	413	533	674	265	376	512	678	875	1109	1236	1343	1453	1567
	BL	1.5	1.5	1.5	1.5	3.0	3.0	3.0	4.5	1.5	1.5	3.0	3.0	3.0	4.5	4.5	4.5	4.5	4.5
22'	TL	---	102	154	221	304	405	516	604	252	362	498	664	830	969	1102	1196	1292	1390
	LL	---	82	122	173	236	312	403	510	200	284	387	512	661	837	1041	1196	1292	1390
	BL	---	1.5	1.5	1.5	1.5	3.0	3.0	3.0	1.5	1.5	1.5	3.0	3.0	3.0	4.5	4.5	4.5	4.5
24'	TL	---	---	117	168	233	311	404	506	192	276	381	509	662	810	935	1069	1162	1249
	LL	---	---	94	134	183	242	312	395	154	219	299	397	512	648	806	987	1162	1249
	BL	---	---	1.5	1.5	1.5	3.0	3.0	3.0	1.5	1.5	1.5	3.0	3.0	3.0	4.5	4.5	4.5	4.5
26'	TL	---	---	90	131	181	243	316	402	148	214	297	398	519	660	792	906	1026	1133
	LL	---	---	74	105	144	191	247	312	122	173	236	313	405	512	637	780	943	1128
	BL	---	---	1.5	1.5	1.5	1.5	3.0	3.0	1.5	1.5	1.5	1.5	3.0	3.0	3.0	4.5	4.5	4.5
28'	TL	---	---	---	103	143	193	252	321	---	169	235	316	413	526	658	777	881	990
	LL	---	---	---	84	116	153	198	251	---	138	189	251	325	412	512	628	759	907
	BL	---	---	---	1.5	1.5	1.5	3.0	3.0	---	1.5	1.5	1.5	3.0	3.0	3.0	3.0	4.5	4.5
30'	TL	---	---	---	82	115	155	203	259	---	134	188	254	332	425	533	656	763	858
	LL	---	---	---	69	94	125	162	205	---	113	154	205	265	336	418	512	620	741
	BL	---	---	---	1.5	1.5	1.5	1.5	3.0	---	1.5	1.5	1.5	1.5	3.0	3.0	3.0	4.5	4.5
32'	TL	---	---	---	---	93	126	165	212	---	---	152	206	271	347	436	538	655	750
	LL	---	---	---	---	78	103	134	169	---	---	127	169	219	278	346	424	512	613
	BL	---	---	---	---	1.5	1.5	1.5	1.5	---	---	1.5	1.5	1.5	1.5	3.0	3.0	3.0	4.5
34'	TL	---	---	---	---	76	103	136	175	---	---	124	169	223	286	361	446	543	653
	LL	---	---	---	---	65	86	112	141	---	---	106	141	183	232	289	354	429	512
	BL	---	---	---	---	1.5	1.5	1.5	1.5	---	---	1.5	1.5	1.5	1.5	3.0	3.0	3.0	3.0
36'	TL	---	---	---	---	---	85	112	145	---	---	---	139	184	238	300	373	455	547
	LL	---	---	---	---	---	73	94	119	---	---	---	119	154	196	244	299	362	433
	BL	---	---	---	---	---	1.5	1.5	1.5	---	---	---	1.5	1.5	1.5	1.5	3.0	3.0	3.0
38'	TL	---	---	---	---	---	---	94	121	---	---	---	---	154	199	252	313	383	462
	LL	---	---	---	---	---	---	80	102	---	---	---	---	131	167	208	255	309	369
	BL	---	---	---	---	---	---	1.5	1.5	---	---	---	---	1.5	1.5	1.5	3.0	3.0	3.0

(See Requirements for Use on page 23, Key and Example on page 29, and Notes on page 29 and this page)

Notes for Table 31: Allowable Roof Loads (plf) - 1.15 Load Duration Factor

- For practicality, allowable roof loads are omitted from the table when they exceed 3,000 and 6,000 pounds per lineal foot (plf) for the 3-1/8" and 5-1/8"-wide beams, respectively, and when a glued laminated timber's span-to-depth ratio exceeds 30.
- To determine allowable roof loads for 3- and 3-1/2"-wide glued laminated timber beams, multiply tabulated total loads (TL) and live loads (LL) for 3-1/8"-wide beams by 0.96 and 1.12, respectively. Then check the required bearing length (BL).
- To determine allowable roof loads for 5- and 5-1/2"-wide glued laminated timber beams, multiply the TL and LL values for 5-1/8" wide beams by 0.976 and 1.073, respectively. Then check the required bearing length (BL).

Table 32 – 24F-1.8E (V3) Southern Pine Glued Laminated Timber																			
Clear Opening		3-1/8" Width									5-1/8" Width								
		Depth (in.)									Depth (in.)								
		8-1/4	9-5/8	11	12-3/8	13-3/4	15-1/8	16-1/2	17-7/8	11	12-3/8	13-3/4	15-1/8	16-1/2	17-7/8	19-1/4	20-5/8	22	23-3/8
6'	TL	1689	2245	2850	---	---	---	---	---	4675	5728	---	---	---	---	---	---	---	---
	LL	1689	2245	2850	---	---	---	---	---	4675	5728	---	---	---	---	---	---	---	---
	BL	3.0	4.5	4.5	---	---	---	---	---	4.5	6.0	---	---	---	---	---	---	---	---
8'	TL	976	1311	1687	2098	2539	---	---	---	2767	3441	4165	4929	5723	---	---	---	---	---
	LL	976	1311	1687	2098	2539	---	---	---	2767	3441	4165	4929	5723	---	---	---	---	---
	BL	3.0	3.0	4.5	4.5	6.0	---	---	---	4.5	4.5	6.0	6.0	7.5	---	---	---	---	---
10'	TL	631	852	1103	1381	1685	2011	2357	2720	1809	2265	2763	3298	3866	4461	5080	5718	---	---
	LL	565	852	1103	1381	1685	2011	2357	2720	1809	2265	2763	3298	3866	4461	5080	5718	---	---
	BL	1.5	3.0	3.0	4.5	4.5	6.0	6.0	7.5	3.0	4.5	4.5	6.0	6.0	7.5	7.5	9.0	---	---
12'	TL	434	595	773	972	1191	1428	1683	1953	1268	1595	1953	2342	2759	3202	3669	4156	4651	5156
	LL	330	520	768	972	1191	1428	1683	1953	1259	1595	1953	2342	2759	3202	3669	4156	4651	5156
	BL	1.5	3.0	3.0	3.0	4.5	4.5	6.0	6.0	3.0	3.0	4.5	4.5	6.0	6.0	7.5	7.5	9.0	9.0
14'	TL	273	433	570	719	883	1062	1255	1462	935	1179	1448	1742	2058	2397	2747	3114	3497	3894
	LL	210	330	489	691	883	1062	1255	1462	802	1133	1448	1742	2058	2397	2747	3114	3497	3894
	BL	1.5	1.5	3.0	3.0	3.0	4.5	4.5	6.0	3.0	3.0	3.0	4.5	4.5	6.0	6.0	6.0	7.5	9.0
16'	TL	182	290	432	552	679	818	969	1131	708	905	1114	1342	1586	1844	2117	2406	2709	3026
	LL	141	223	330	467	636	818	969	1131	542	766	1043	1342	1586	1844	2117	2406	2709	3026
	BL	1.5	1.5	3.0	3.0	3.0	3.0	4.5	4.5	3.0	3.0	3.0	3.0	4.5	4.5	6.0	6.0	6.0	7.5
18'	TL	126	202	303	431	537	648	769	899	497	706	881	1059	1251	1457	1676	1908	2153	2409
	LL	100	157	234	330	450	596	768	899	383	542	739	977	1251	1457	1676	1908	2153	2409
	BL	1.5	1.5	1.5	3.0	3.0	3.0	4.5	4.5	1.5	3.0	3.0	3.0	4.5	4.5	4.5	6.0	6.0	6.0
20'	TL	90	146	220	313	430	525	624	730	360	514	705	854	1010	1177	1356	1546	1747	1957
	LL	73	115	171	242	330	437	565	713	281	398	542	717	926	1171	1356	1546	1747	1957
	BL	1.5	1.5	1.5	1.5	3.0	3.0	3.0	4.5	1.5	1.5	3.0	3.0	3.0	4.5	4.5	4.5	6.0	6.0
22'	TL	---	108	163	234	322	428	516	604	268	384	528	701	830	969	1118	1275	1442	1618
	LL	---	87	129	183	250	330	427	540	212	300	409	542	700	886	1101	1275	1442	1618
	BL	---	1.5	1.5	1.5	3.0	3.0	3.0	3.0	1.5	1.5	3.0	3.0	3.0	3.0	4.5	4.5	4.5	6.0
24'	TL	---	---	124	179	247	329	427	506	204	293	405	540	693	810	935	1068	1209	1357
	LL	---	---	100	141	193	256	330	418	163	232	317	420	542	686	853	1045	1209	1357
	BL	---	---	1.5	1.5	1.5	3.0	3.0	3.0	1.5	1.5	1.5	3.0	3.0	3.0	3.0	4.5	4.5	4.5
26'	TL	---	---	96	139	192	257	335	426	157	228	315	422	550	686	792	906	1026	1153
	LL	---	---	78	111	152	202	261	330	129	183	250	331	428	542	674	826	999	1153
	BL	---	---	1.5	1.5	1.5	1.5	3.0	3.0	1.5	1.5	1.5	1.5	3.0	3.0	3.0	4.5	4.5	4.5
28'	TL	---	---	---	109	152	204	267	340	---	179	250	335	438	558	679	777	881	990
	LL	---	---	---	89	122	162	210	266	---	147	201	266	344	436	542	665	804	960
	BL	---	---	---	1.5	1.5	1.5	3.0	3.0	---	1.5	1.5	1.5	3.0	3.0	3.0	3.0	4.5	4.5
30'	TL	---	---	---	87	122	164	215	275	---	143	200	270	353	451	565	673	763	858
	LL	---	---	---	73	100	132	171	217	---	119	163	217	281	356	442	542	656	784
	BL	---	---	---	1.5	1.5	1.5	1.5	3.0	---	1.5	1.5	1.5	1.5	3.0	3.0	3.0	4.5	4.5
32'	TL	---	---	---	---	99	134	175	225	---	---	162	219	288	369	463	571	666	750
	LL	---	---	---	---	82	109	141	179	---	---	135	179	232	294	366	448	542	649
	BL	---	---	---	---	1.5	1.5	1.5	3.0	---	---	1.5	1.5	1.5	3.0	3.0	3.0	3.0	4.5
34'	TL	---	---	---	---	81	110	144	186	---	---	132	180	237	304	383	473	576	660
	LL	---	---	---	---	69	91	118	150	---	---	112	149	194	246	306	375	453	542
	BL	---	---	---	---	1.5	1.5	1.5	1.5	---	---	1.5	1.5	1.5	1.5	3.0	3.0	3.0	3.0
36'	TL	---	---	---	---	---	91	120	154	---	---	---	148	196	253	319	396	483	581
	LL	---	---	---	---	---	77	100	126	---	---	---	126	163	207	258	317	383	458
	BL	---	---	---	---	---	1.5	1.5	1.5	---	---	---	1.5	1.5	1.5	3.0	3.0	3.0	3.0
38'	TL	---	---	---	---	---	---	100	129	---	---	---	---	164	212	268	333	407	491
	LL	---	---	---	---	---	---	85	108	---	---	---	---	139	176	220	270	327	391
	BL	---	---	---	---	---	---	---	1.5	---	---	---	---	---	1.5	1.5	1.5	3.0	3.0

(See Requirements for Use on page 23, Key and Example on page 29, and Notes on page 29 and this page)

Notes for Table 32: Allowable Roof Loads (plf) - 1.15 Load Duration Factor

- For practicality, allowable roof loads are omitted from the table when they exceed 3,000 and 6,000 pounds per lineal foot (plf) for the 3-1/8" and 5-1/8"-wide beams, respectively, and when a glued laminated timber's span-to-depth ratio exceeds 30.
- To determine allowable roof loads for 3- and 3-1/2"-wide glued laminated timber beams, multiply tabulated total loads (TL) and live loads (LL) for 3-1/8"-wide beams by 0.96 and 1.12, respectively. Then check the required bearing length (BL).
- To determine allowable roof loads for 5- and 5-1/2"-wide glued laminated timber beams, multiply the TL and LL values for 5-1/8" wide beams by 0.976 or 1.073, respectively. Then check the required bearing length (BL).

Key – for each clear opening there are three rows of values:

- TL: Maximum total load in pounds per lineal foot (plf) with deflection limited to $\ell/180$
- LL: Maximum live load in pounds per lineal foot (plf) with deflection limited to $\ell/240$
- BL: Required bearing length in inches

Steps in Sizing Headers or Beams:

1. Determine the required total load (live load + dead load) in plf.
2. Determine the required live load in plf.
3. Select a clear opening and find columns where the plf value in the TL row equals or exceeds the required total load, *and* the plf value in the LL row equals or exceeds the required live load.
4. Check required bearing lengths in the BL row.
5. Find product size options at the top of the columns meeting the total load, live load and bearing length requirements.

Example: Allowable Roof Loads

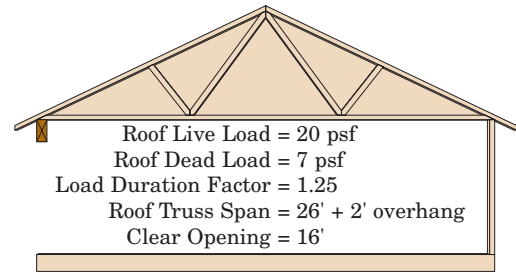

Total Load = $(26'/2 + 2') \times (20 + 7) \text{ psf} = 405 \text{ plf}$
 Live Load = $(26'/2 + 2') \times 20 \text{ psf} = 300 \text{ plf}$

Select the 16' clear opening in Tables 33-38. Read across the TL row in each table to find columns with total loads equal to or greater than the required 405 plf. Then check the LL row in those columns to make sure the corresponding live loads are equal to or greater than the required 300 plf. Solutions include: from Table 33 for No. 1 SP lumber, select (4) 2x12s requiring a 1.5" bearing length; from Table 36 for 24F-1.7E (V4) SP glulam, select a 3-1/2x11-1/4" beam requiring a 3.0" bearing length. From Table 38 for 24F-1.8E (V3) SP glulam, select a 3-1/8x11" beam requiring a 3.0" bearing length.

Table 33 – No. 1 Southern Pine Lumber

Clear Opening		1-ply				2-ply				3-ply				4-ply			
		2 x 6	2 x 8	2 x 10	2 x 12	2 x 6	2 x 8	2 x 10	2 x 12	2 x 6	2 x 8	2 x 10	2 x 12	2 x 6	2 x 8	2 x 10	2 x 12
4'	TL	502	783	1036	1389	1005	1565	2072	2778	1720	2666	3512	4671	2293	3554	4682	6228
	LL	502	783	1036	1389	1005	1565	2072	2778	1720	2666	3512	4671	2293	3554	4682	6228
	BL	1.5	3.0	3.0	4.5	1.5	3.0	3.0	4.5	1.5	3.0	3.0	4.5	1.5	3.0	3.0	4.5
6'	TL	229	364	490	677	458	727	981	1353	788	1248	1680	2310	1050	1664	2240	3080
	LL	229	364	490	677	458	727	981	1353	788	1248	1680	2310	1050	1664	2240	3080
	BL	1.5	1.5	3.0	3.0	1.5	1.5	3.0	3.0	1.5	3.0	3.0	3.0	1.5	3.0	3.0	3.0
8'	TL	129	207	281	391	258	414	562	783	446	712	966	1344	594	950	1288	1792
	LL	129	207	281	391	258	414	562	783	424	712	966	1344	565	950	1288	1792
	BL	1.5	1.5	1.5	3.0	1.5	1.5	1.5	3.0	1.5	1.5	3.0	3.0	1.5	1.5	3.0	3.0
10'	TL	82	132	180	253	165	265	361	506	285	457	622	871	380	610	830	1161
	LL	73	132	180	253	146	265	361	506	219	457	622	871	292	610	830	1161
	BL	1.5	1.5	1.5	3.0	1.5	1.5	1.5	3.0	1.5	1.5	1.5	3.0	1.5	1.5	1.5	3.0
12'	TL	55	92	125	176	109	183	250	352	164	317	432	607	218	422	576	809
	LL	42	92	125	176	85	183	250	352	127	289	432	607	170	386	576	809
	BL	1.5	1.5	1.5	1.5	1.5	1.5	1.5	1.5	1.5	1.5	1.5	1.5	1.5	1.5	1.5	1.5
14'	TL	34	67	91	129	68	134	183	257	101	231	316	445	135	308	421	593
	LL	27	61	91	129	54	122	183	257	80	183	316	445	107	244	421	593
	BL	1.5	1.5	1.5	1.5	1.5	1.5	1.5	1.5	1.5	1.5	1.5	1.5	1.5	1.5	1.5	1.5
16'	TL	22	51	69	98	44	101	139	196	66	156	240	339	88	208	320	452
	LL	18	41	69	98	36	82	139	196	54	123	240	339	72	164	320	452
	BL	1.5	1.5	1.5	1.5	1.5	1.5	1.5	1.5	1.5	1.5	1.5	1.5	1.5	1.5	1.5	1.5
18'	TL	15	36	54	77	30	72	108	153	45	108	188	266	60	144	251	355
	LL	13	29	54	77	25	58	108	153	38	87	179	266	51	116	239	355
	BL	1.5	1.5	1.5	1.5	1.5	1.5	1.5	1.5	1.5	1.5	1.5	1.5	1.5	1.5	1.5	1.5

(See *Requirements for Use* on page 23, and *Key, Example and Notes* on this page)

Notes for Tables 33 - 38: Allowable Roof Loads (plf) - 1.25 Load Duration Factor

- Tabulated total loads (TL) and live loads (LL) represent the allowable uniformly distributed loads that a beam can support in addition to its own weight. Deflection is limited to $\ell/180$ for total load and $\ell/240$ for live load. To determine an allowable live load for a deflection limit other than $\ell/240$, multiply the LL value by the ratio of 240 divided by the desired deflection constant. The result must not exceed the corresponding TL value for the same clear opening and product.
- Tabulated bearing lengths (BL) reflect the number of 2x trimmers required at each end of the header or beam based on the corresponding plf loads (e.g., 1.5" = one trimmer, 3.0" = two trimmers, etc.). Additional checks may be required for bearing length and trimmers.
- See *Assumptions for Table Development* beginning on page 2 for details on design assumptions made to generate these tables.
- Interpolation between clear openings is permitted.
- The design span is assumed to be the clear opening plus 1/2 the required bearing length at each end.

Table 34 – No. 2 Southern Pine Lumber																	
Clear Opening		1-ply				2-ply				3-ply				4-ply			
		2 x 6	2 x 8	2 x 10	2 x 12	2 x 6	2 x 8	2 x 10	2 x 12	2 x 6	2 x 8	2 x 10	2 x 12	2 x 6	2 x 8	2 x 10	2 x 12
4'	TL	377	592	812	1087	754	1183	1623	2174	1293	2023	2764	3679	1724	2697	3685	4906
	LL	377	592	812	1087	754	1183	1623	2174	1293	2023	2764	3679	1724	2697	3685	4906
	BL	1.5	1.5	3.0	3.0	1.5	1.5	3.0	3.0	1.5	3.0	3.0	4.5	1.5	3.0	3.0	4.5
6'	TL	170	271	378	516	340	542	755	1032	586	932	1296	1767	782	1243	1728	2356
	LL	170	271	378	516	340	542	755	1032	586	932	1296	1767	782	1243	1728	2356
	BL	1.5	1.5	1.5	3.0	1.5	1.5	1.5	3.0	1.5	1.5	3.0	3.0	1.5	1.5	3.0	3.0
8'	TL	96	153	215	296	191	306	429	591	330	529	740	1017	440	705	986	1356
	LL	96	153	215	296	191	306	429	591	330	529	740	1017	440	705	986	1356
	BL	1.5	1.5	1.5	1.5	1.5	1.5	1.5	1.5	1.5	1.5	1.5	3.0	1.5	1.5	1.5	3.0
10'	TL	61	98	137	190	121	195	275	380	210	338	474	655	280	450	632	873
	LL	61	98	137	190	121	195	275	380	192	338	474	655	256	450	632	873
	BL	1.5	1.5	1.5	1.5	1.5	1.5	1.5	1.5	1.5	1.5	1.5	1.5	1.5	1.5	1.5	1.5
12'	TL	42	67	95	131	83	135	190	263	143	233	328	454	190	311	437	606
	LL	37	67	95	131	74	135	190	263	112	233	328	454	149	311	437	606
	BL	1.5	1.5	1.5	1.5	1.5	1.5	1.5	1.5	1.5	1.5	1.5	1.5	1.5	1.5	1.5	1.5
14'	TL	29	49	69	96	59	98	138	192	88	169	239	332	117	226	319	443
	LL	23	49	69	96	47	98	138	192	70	161	239	332	94	214	319	443
	BL	1.5	1.5	1.5	1.5	1.5	1.5	1.5	1.5	1.5	1.5	1.5	1.5	1.5	1.5	1.5	1.5
16'	TL	19	37	52	73	38	74	104	145	57	128	181	252	76	171	241	336
	LL	16	36	52	73	31	72	104	145	47	108	181	252	63	144	241	336
	BL	1.5	1.5	1.5	1.5	1.5	1.5	1.5	1.5	1.5	1.5	1.5	1.5	1.5	1.5	1.5	1.5
18'	TL	13	29	41	57	26	57	81	113	38	93	141	197	51	124	188	263
	LL	11	25	41	57	22	51	81	113	33	76	141	197	44	101	188	263
	BL	1.5	1.5	1.5	1.5	1.5	1.5	1.5	1.5	1.5	1.5	1.5	1.5	1.5	1.5	1.5	1.5

Table 35 – No. 3 Southern Pine Lumber																	
Clear Opening		1-ply				2-ply				3-ply				4-ply			
		2 x 6	2 x 8	2 x 10	2 x 12	2 x 6	2 x 8	2 x 10	2 x 12	2 x 6	2 x 8	2 x 10	2 x 12	2 x 6	2 x 8	2 x 10	2 x 12
4'	TL	219	344	499	685	439	688	997	1369	756	1182	1708	2337	1007	1576	2278	3116
	LL	219	344	499	685	439	688	997	1369	756	1182	1708	2337	1007	1576	2278	3116
	BL	1.5	1.5	1.5	3.0	1.5	1.5	1.5	3.0	1.5	1.5	1.5	3.0	1.5	1.5	1.5	3.0
6'	TL	98	155	226	315	195	309	453	630	337	533	780	1083	450	711	1040	1444
	LL	98	155	226	315	195	309	453	630	337	533	780	1083	450	711	1040	1444
	BL	1.5	1.5	1.5	1.5	1.5	1.5	1.5	1.5	1.5	1.5	1.5	1.5	1.5	1.5	1.5	1.5
8'	TL	54	86	127	178	109	173	255	356	188	299	440	614	251	399	586	819
	LL	54	86	127	178	109	173	255	356	188	299	440	614	251	399	586	819
	BL	1.5	1.5	1.5	1.5	1.5	1.5	1.5	1.5	1.5	1.5	1.5	1.5	1.5	1.5	1.5	1.5
10'	TL	34	55	81	113	68	109	161	227	119	189	279	392	158	252	373	522
	LL	34	55	81	113	68	109	161	227	119	189	279	392	158	252	373	522
	BL	1.5	1.5	1.5	1.5	1.5	1.5	1.5	1.5	1.5	1.5	1.5	1.5	1.5	1.5	1.5	1.5
12'	TL	23	37	55	78	46	74	110	155	81	129	192	270	108	172	255	359
	LL	23	37	55	78	46	74	110	155	81	129	192	270	108	172	255	359
	BL	1.5	1.5	1.5	1.5	1.5	1.5	1.5	1.5	1.5	1.5	1.5	1.5	1.5	1.5	1.5	1.5
14'	TL	16	27	40	56	33	53	79	112	58	93	138	195	77	124	185	260
	LL	16	27	40	56	33	53	79	112	58	93	138	195	77	124	185	260
	BL	1.5	1.5	1.5	1.5	1.5	1.5	1.5	1.5	1.5	1.5	1.5	1.5	1.5	1.5	1.5	1.5
16'	TL	12	20	30	42	24	40	59	84	43	70	104	147	57	93	138	196
	LL	12	20	30	42	24	40	59	84	43	70	104	147	57	93	138	196
	BL	1.5	1.5	1.5	1.5	1.5	1.5	1.5	1.5	1.5	1.5	1.5	1.5	1.5	1.5	1.5	1.5
18'	TL	9	15	23	32	18	30	46	65	33	53	80	114	44	71	107	152
	LL	9	15	23	32	18	30	46	65	31	53	80	114	41	71	107	152
	BL	1.5	1.5	1.5	1.5	1.5	1.5	1.5	1.5	1.5	1.5	1.5	1.5	1.5	1.5	1.5	1.5

(See Requirements for Use on page 23, and Key, Example and Notes on page 34)

Table 36 – 24F-1.7E (V4) Southern Pine Glued Laminated Timber

Clear Opening		3-1/2" Width								5-1/2" Width								
		Depth (in.)								Depth (in.)								
		9-1/4	9-1/2	11-1/4	11-7/8	14	16	18	19-1/4	11-1/4	11-7/8	14	16	18	19-1/4	20-5/8	22	23-3/8
6'	TL	2110	2187	2774	---	---	---	---	---	3484	3774	4881	---	---	---	---	---	
	LL	2110	2187	2774	---	---	---	---	---	3484	3774	4881	---	---	---	---	---	
	BL	3.0	3.0	4.5	---	---	---	---	---	3.0	3.0	4.5	---	---	---	---	---	
8'	TL	1454	1503	1865	2003	2510	---	---	---	2342	2515	3151	3828	4595	5129	5773	---	
	LL	1454	1503	1865	2003	2510	---	---	---	2342	2515	3151	3828	4595	5129	5773	---	
	BL	3.0	3.0	3.0	4.5	4.5	---	---	---	3.0	3.0	4.5	4.5	6.0	6.0	7.5	---	
10'	TL	958	1009	1400	1501	1852	2213	2609	2876	1761	1884	2324	2778	3275	3611	4005	4427	4882
	LL	831	898	1400	1501	1852	2213	2609	2876	1761	1884	2324	2778	3275	3611	4005	4427	4882
	BL	3.0	3.0	3.0	3.0	4.5	4.5	6.0	6.0	3.0	3.0	3.0	4.5	4.5	6.0	6.0	6.0	7.5
12'	TL	643	695	982	1090	1466	1736	2026	2218	1410	1504	1839	2178	2542	2783	3063	3358	3669
	LL	488	528	864	1010	1466	1736	2026	2218	1365	1504	1839	2178	2542	2783	3063	3358	3669
	BL	3.0	3.0	3.0	3.0	4.5	4.5	6.0	6.0	3.0	3.0	3.0	4.5	4.5	4.5	6.0	6.0	6.0
14'	TL	407	441	725	806	1111	1427	1655	1804	1139	1251	1521	1790	2075	2263	2477	2702	2936
	LL	311	337	551	646	1041	1427	1655	1804	866	1016	1521	1790	2075	2263	2477	2702	2936
	BL	1.5	1.5	3.0	3.0	4.5	4.5	6.0	6.0	3.0	3.0	3.0	4.5	4.5	4.5	4.5	6.0	6.0
16'	TL	272	295	488	573	855	1109	1394	1519	767	900	1295	1518	1752	1905	2078	2259	2446
	LL	210	227	374	438	707	1041	1394	1519	587	688	1114	1518	1752	1905	2078	2259	2446
	BL	1.5	1.5	3.0	3.0	3.0	4.5	4.5	6.0	3.0	3.0	3.0	4.5	4.5	4.5	4.5	6.0	6.0
18'	TL	189	205	343	403	656	881	1107	1261	538	633	1031	1317	1515	1643	1789	1939	2094
	LL	148	160	264	310	501	740	1041	1261	415	487	788	1167	1515	1643	1789	1939	2094
	BL	1.5	1.5	1.5	1.5	3.0	4.5	4.5	4.5	1.5	1.5	3.0	3.0	4.5	4.5	4.5	4.5	4.5
20'	TL	136	148	248	293	479	711	901	1024	390	460	753	1106	1334	1445	1570	1698	1830
	LL	108	117	194	227	369	544	767	932	304	357	580	855	1210	1445	1570	1698	1830
	BL	1.5	1.5	1.5	1.5	3.0	3.0	4.5	4.5	1.5	1.5	3.0	3.0	4.5	4.5	4.5	4.5	6.0
22'	TL	100	109	185	218	359	536	743	845	290	343	565	842	1142	1288	1397	1510	1625
	LL	81	88	146	171	279	412	581	707	229	269	438	648	914	1114	1365	1510	1625
	BL	1.5	1.5	1.5	1.5	3.0	3.0	4.5	4.5	1.5	1.5	3.0	3.0	4.5	4.5	4.5	4.5	6.0
24'	TL	---	---	140	166	275	412	586	708	220	261	432	648	920	1087	1242	1358	1460
	LL	---	---	113	132	216	320	451	548	177	208	339	502	709	863	1056	1278	1460
	BL	---	---	1.5	1.5	1.5	3.0	3.0	4.5	1.5	1.5	1.5	3.0	3.0	4.5	4.5	4.5	4.5
26'	TL	---	---	108	129	214	323	460	562	170	202	337	507	723	884	1053	1193	1325
	LL	---	---	89	104	170	253	357	434	139	164	267	397	561	683	835	1009	1207
	BL	---	---	1.5	1.5	1.5	3.0	3.0	3.0	1.5	1.5	1.5	3.0	3.0	3.0	4.5	4.5	4.5
28'	TL	---	---	85	101	170	256	367	450	---	159	267	403	577	706	868	1024	1151
	LL	---	---	71	84	137	203	287	350	---	131	215	319	451	550	673	812	970
	BL	---	---	1.5	1.5	1.5	1.5	3.0	3.0	---	1.5	1.5	1.5	3.0	3.0	4.5	4.5	4.5
30'	TL	---	---	---	---	136	206	297	364	---	---	214	324	466	572	704	855	999
	LL	---	---	---	---	111	165	234	286	---	---	175	260	368	449	550	664	793
	BL	---	---	---	---	1.5	1.5	3.0	3.0	---	---	1.5	1.5	3.0	3.0	3.0	4.5	4.5
32'	TL	---	---	---	---	110	168	242	298	---	---	173	264	381	468	578	703	843
	LL	---	---	---	---	92	137	194	236	---	---	144	215	304	371	455	550	656
	BL	---	---	---	---	1.5	1.5	3.0	3.0	---	---	1.5	1.5	3.0	3.0	3.0	3.0	4.5
34'	TL	---	---	---	---	90	138	200	246	---	---	141	217	314	387	479	583	701
	LL	---	---	---	---	77	114	162	197	---	---	120	179	254	310	380	460	550
	BL	---	---	---	---	1.5	1.5	1.5	3.0	---	---	1.5	1.5	1.5	3.0	3.0	3.0	3.0
36'	TL	---	---	---	---	114	166	205	---	---	---	179	261	322	400	488	587	
	LL	---	---	---	---	96	137	167	---	---	---	151	215	262	321	389	465	
	BL	---	---	---	---	1.5	1.5	1.5	---	---	---	1.5	1.5	1.5	3.0	3.0	3.0	
38'	TL	---	---	---	---	95	139	172	---	---	---	149	219	271	336	411	496	
	LL	---	---	---	---	82	116	142	---	---	---	129	183	223	274	331	396	
	BL	---	---	---	---	1.5	1.5	1.5	---	---	---	1.5	1.5	1.5	3.0	3.0	3.0	

(See Requirements for Use on page 23, Key and Example on page 34, and Notes on page 34 and this page)

Notes for Table 36: Allowable Roof Loads (plf) - 1.25 Load Duration Factor

- For practicality, allowable roof loads are omitted from the table when they exceed 3,000 and 6,000 pounds per lineal foot (plf) for the 3-1/2" and 5-1/2"-wide beams, respectively, and when a glued laminated timber's span-to-depth ratio exceeds 30.
- To determine allowable roof loads for 3- and 3-1/8"-wide glued laminated timber beams, multiply tabulated total loads (TL) and live loads (LL) for 3-1/2"-wide beams by 0.857 and 0.893, respectively. Then check the required bearing length (BL).
- To determine allowable roof loads for 5- and 5-1/8"-wide glued laminated timber beams, multiply the TL and LL values for 5-1/2" wide beams by 0.909 or 0.932, respectively. Then check the required bearing length (BL).

Table 37 – 24F-1.7E (V4) Southern Pine Glued Laminated Timber																			
Clear Opening		3-1/8" Width								5-1/8" Width									
		Depth (in.)								Depth (in.)									
		8-1/4	9-5/8	11	12-3/8	13-3/4	15-1/8	16-1/2	17-7/8	11	12-3/8	13-3/4	15-1/8	16-1/2	17-7/8	19-1/4	20-5/8	22	23-3/8
6'	TL	1619	1988	2398	2855	---	---	---	---	3143	3742	4416	5179	---	---	---	---	---	---
	LL	1619	1988	2398	2855	---	---	---	---	3143	3742	4416	5179	---	---	---	---	---	---
	BL	3.0	3.0	4.5	4.5	---	---	---	---	3.0	4.5	4.5	4.5	---	---	---	---	---	---
8'	TL	1058	1364	1617	1890	2185	2504	2852	---	2119	2476	2863	3282	3737	4234	4779	5379	---	---
	LL	1016	1364	1617	1890	2185	2504	2852	---	2119	2476	2863	3282	3737	4234	4779	5379	---	---
	BL	3.0	3.0	3.0	4.5	4.5	6.0	6.0	---	3.0	3.0	4.5	4.5	4.5	6.0	6.0	7.5	---	---
10'	TL	684	924	1197	1411	1615	1831	2061	2306	1597	1848	2115	2399	2700	3021	3365	3732	4126	4549
	LL	532	832	1197	1411	1615	1831	2061	2306	1597	1848	2115	2399	2700	3021	3365	3732	4126	4549
	BL	1.5	3.0	3.0	4.5	4.5	4.5	6.0	6.0	3.0	3.0	3.0	4.5	4.5	4.5	6.0	6.0	6.0	7.5
12'	TL	410	645	839	1054	1280	1442	1613	1792	1280	1473	1676	1889	2112	2346	2594	2854	3129	3419
	LL	312	489	722	1016	1280	1442	1613	1792	1191	1473	1676	1889	2112	2346	2594	2854	3129	3419
	BL	1.5	3.0	3.0	3.0	4.5	4.5	4.5	6.0	3.0	3.0	3.0	4.5	4.5	4.5	4.5	6.0	6.0	6.0
14'	TL	258	409	606	780	958	1152	1324	1464	994	1224	1387	1556	1733	1916	2108	2308	2518	2736
	LL	198	312	461	650	882	1152	1324	1464	756	1069	1387	1556	1733	1916	2108	2308	2518	2736
	BL	1.5	1.5	3.0	3.0	3.0	4.5	4.5	6.0	3.0	3.0	3.0	3.0	4.5	4.5	4.5	4.5	6.0	6.0
16'	TL	172	274	408	577	737	888	1051	1228	669	947	1182	1322	1468	1619	1775	1937	2105	2279
	LL	134	211	312	440	599	790	1016	1228	512	722	984	1304	1468	1619	1775	1937	2105	2279
	BL	1.5	1.5	1.5	3.0	3.0	4.5	4.5	4.5	1.5	3.0	3.0	3.0	4.5	4.5	4.5	4.5	6.0	6.0
18'	TL	119	191	286	407	556	704	835	976	469	667	911	1149	1273	1400	1531	1667	1807	1952
	LL	94	149	221	312	425	561	722	911	362	512	697	921	1191	1400	1531	1667	1807	1952
	BL	1.5	1.5	1.5	3.0	3.0	3.0	4.5	4.5	1.5	3.0	3.0	3.0	4.5	4.5	4.5	4.5	4.5	6.0
20'	TL	85	137	207	296	406	538	678	793	339	485	665	883	1097	1233	1346	1463	1582	1706
	LL	69	109	162	229	312	413	532	671	265	376	512	677	872	1105	1346	1463	1582	1706
	BL	1.5	1.5	1.5	1.5	3.0	3.0	3.0	4.5	1.5	1.5	3.0	3.0	3.0	4.5	4.5	4.5	4.5	6.0
22'	TL	---	102	154	221	304	405	524	657	252	362	498	664	859	1053	1200	1302	1407	1514
	LL	---	82	122	173	236	312	403	508	200	284	387	512	661	834	1038	1272	1407	1514
	BL	---	1.5	1.5	1.5	1.5	3.0	3.0	4.5	1.5	1.5	1.5	3.0	3.0	4.5	4.5	4.5	4.5	6.0
24'	TL	---	---	117	168	233	311	404	512	192	276	381	509	662	840	1017	1161	1265	1360
	LL	---	---	94	134	183	242	312	395	154	219	299	397	512	647	804	984	1191	1360
	BL	---	---	1.5	1.5	1.5	3.0	3.0	3.0	1.5	1.5	1.5	3.0	3.0	3.0	4.5	4.5	4.5	4.5
26'	TL	---	---	90	131	181	243	316	402	148	214	297	398	519	660	823	985	1116	1234
	LL	---	---	74	105	144	191	247	312	122	173	236	313	405	512	636	778	940	1124
	BL	---	---	1.5	1.5	1.5	1.5	3.0	3.0	1.5	1.5	1.5	1.5	3.0	3.0	3.0	4.5	4.5	4.5
28'	TL	---	---	---	103	143	193	252	321	---	169	235	316	413	526	658	809	958	1077
	LL	---	---	---	84	116	153	198	251	---	138	189	251	325	412	512	627	757	904
	BL	---	---	---	1.5	1.5	1.5	3.0	3.0	---	1.5	1.5	1.5	3.0	3.0	3.0	4.5	4.5	4.5
30'	TL	---	---	---	82	115	155	203	259	---	134	188	254	332	425	533	656	796	934
	LL	---	---	---	69	94	125	162	205	---	113	154	205	265	336	418	512	619	739
	BL	---	---	---	1.5	1.5	1.5	1.5	3.0	---	1.5	1.5	1.5	1.5	3.0	3.0	3.0	4.5	4.5
32'	TL	---	---	---	---	93	126	165	212	---	---	152	206	271	347	436	538	655	785
	LL	---	---	---	---	78	103	134	169	---	---	127	169	219	278	346	424	512	612
	BL	---	---	---	---	1.5	1.5	1.5	1.5	---	---	1.5	1.5	1.5	1.5	3.0	3.0	3.0	4.5
34'	TL	---	---	---	---	76	103	136	175	---	---	124	169	223	286	361	446	543	653
	LL	---	---	---	---	65	86	112	141	---	---	106	141	183	232	289	354	429	512
	BL	---	---	---	---	1.5	1.5	1.5	1.5	---	---	1.5	1.5	1.5	1.5	3.0	3.0	3.0	3.0
36'	TL	---	---	---	---	---	85	112	145	---	---	---	139	184	238	300	373	455	547
	LL	---	---	---	---	---	73	94	119	---	---	---	119	154	196	244	299	362	433
	BL	---	---	---	---	---	1.5	1.5	1.5	---	---	---	1.5	1.5	1.5	1.5	3.0	3.0	3.0
38'	TL	---	---	---	---	---	---	94	121	---	---	---	---	154	199	252	313	383	462
	LL	---	---	---	---	---	---	80	102	---	---	---	---	131	167	208	255	309	369
	BL	---	---	---	---	---	---	1.5	1.5	---	---	---	---	1.5	1.5	1.5	3.0	3.0	3.0

(See Requirements for Use on page 23, Key and Example on page 34, and Notes on page 34 and this page)

Notes for Table 37: Allowable Roof Loads (plf) - 1.25 Load Duration Factor

- For practicality, allowable roof loads are omitted from the table when they exceed 3,000 and 6,000 pounds per lineal foot (plf) for the 3-1/8" and 5-1/8"-wide beams, respectively, and when a glued laminated timber's span-to-depth ratio exceeds 30.
- To determine allowable roof loads for 3- and 3-1/2"-wide glued laminated timber beams, multiply tabulated total loads (TL) and live loads (LL) for 3-1/8"-wide beams by 0.96 and 1.12, respectively. Then check the required bearing length (BL).
- To determine allowable roof loads for 5- and 5-1/2"-wide glued laminated timber beams, multiply the TL and LL values for 5-1/8" wide beams by 0.976 or 1.073, respectively. Then check the required bearing length (BL).

Table 38 – 24F-1.8E (V3) Southern Pine Glued Laminated Timber

Clear Opening		3-1/8" Width									5-1/8" Width								
		Depth (in.)									Depth (in.)								
		8-1/4	9-5/8	11	12-3/8	13-3/4	15-1/8	16-1/2	17-7/8	11	12-3/8	13-3/4	15-1/8	16-1/2	17-7/8	19-1/4	20-5/8	22	23-3/8
6'	TL	1826	2421	---	---	---	---	---	---	5029	---	---	---	---	---	---	---	---	
	LL	1826	2421	---	---	---	---	---	---	5029	---	---	---	---	---	---	---	---	
	BL	3.0	4.5	---	---	---	---	---	---	4.5	---	---	---	---	---	---	---	---	
8'	TL	1058	1419	1824	2264	2736	---	---	---	2991	3714	4486	5298	---	---	---	---	---	
	LL	1058	1419	1824	2264	2736	---	---	---	2991	3714	4486	5298	---	---	---	---	---	
	BL	3.0	3.0	4.5	4.5	6.0	---	---	---	4.5	4.5	6.0	6.0	---	---	---	---	---	
10'	TL	684	924	1195	1495	1821	2171	2541	2928	1960	2452	2987	3561	4168	4802	5459	---	---	
	LL	563	881	1195	1495	1821	2171	2541	2928	1960	2452	2987	3561	4168	4802	5459	---	---	
	BL	1.5	3.0	3.0	4.5	4.5	6.0	6.0	7.5	3.0	4.5	4.5	6.0	6.0	7.5	9.0	---	---	
12'	TL	434	646	839	1054	1290	1546	1819	2109	1376	1729	2116	2535	2984	3459	3958	4477	5004	
	LL	330	518	765	1054	1290	1546	1819	2109	1255	1729	2116	2535	2984	3459	3958	4477	5004	
	BL	1.5	3.0	3.0	3.0	4.5	4.5	6.0	6.0	3.0	3.0	4.5	4.5	6.0	6.0	7.5	7.5	9.0	
14'	TL	273	433	620	780	958	1151	1360	1582	1016	1280	1571	1888	2230	2594	2971	3364	3774	
	LL	210	330	488	688	934	1151	1360	1582	800	1129	1532	1888	2230	2594	2971	3364	3774	
	BL	1.5	1.5	3.0	3.0	3.0	4.5	4.5	6.0	3.0	3.0	3.0	4.5	4.5	6.0	6.0	7.5	7.5	
16'	TL	182	290	432	599	737	888	1051	1226	708	983	1209	1456	1720	1998	2293	2605	2930	
	LL	141	223	330	466	634	836	1051	1226	542	764	1040	1372	1720	1998	2293	2605	2930	
	BL	1.5	1.5	3.0	3.0	3.0	4.5	4.5	4.5	3.0	3.0	3.0	4.5	4.5	4.5	6.0	6.0	7.5	
18'	TL	126	202	303	431	584	704	835	976	497	706	957	1151	1358	1581	1818	2068	2332	
	LL	100	157	234	330	449	594	765	965	383	542	737	974	1255	1581	1818	2068	2332	
	BL	1.5	1.5	1.5	3.0	3.0	3.0	4.5	4.5	1.5	3.0	3.0	3.0	4.5	4.5	4.5	6.0	6.0	
20'	TL	90	146	220	313	430	570	678	793	360	514	704	928	1097	1279	1472	1678	1894	
	LL	73	115	171	242	330	436	563	711	281	398	542	716	923	1167	1447	1678	1894	
	BL	1.5	1.5	1.5	1.5	3.0	3.0	3.0	4.5	1.5	1.5	3.0	3.0	3.0	4.5	4.5	6.0	6.0	
22'	TL	---	108	163	234	322	428	555	657	268	384	528	703	903	1053	1214	1385	1566	
	LL	---	87	129	183	250	330	426	538	212	300	409	542	699	883	1097	1341	1566	
	BL	---	1.5	1.5	1.5	3.0	3.0	3.0	4.5	1.5	1.5	3.0	3.0	3.0	4.5	4.5	4.5	6.0	
24'	TL	---	---	124	179	247	329	427	542	204	293	405	540	701	881	1017	1161	1313	
	LL	---	---	100	141	193	256	330	417	163	232	317	420	542	685	851	1041	1257	
	BL	---	---	1.5	1.5	1.5	3.0	3.0	3.0	1.5	1.5	1.5	3.0	3.0	3.0	4.5	4.5	4.5	
26'	TL	---	---	96	139	192	257	335	426	157	228	315	422	550	699	862	985	1116	
	LL	---	---	78	111	152	202	261	330	129	183	250	331	428	542	673	824	995	
	BL	---	---	1.5	1.5	1.5	1.5	3.0	3.0	1.5	1.5	1.5	1.5	3.0	3.0	3.0	4.5	4.5	
28'	TL	---	---	---	109	152	204	267	340	---	179	250	335	438	558	697	845	958	
	LL	---	---	---	89	122	162	210	266	---	147	201	266	344	436	542	663	801	
	BL	---	---	---	1.5	1.5	1.5	3.0	3.0	---	1.5	1.5	1.5	3.0	3.0	3.0	4.5	4.5	
30'	TL	---	---	---	87	122	164	215	275	---	143	200	270	353	451	565	696	830	
	LL	---	---	---	73	100	132	171	217	---	119	163	217	281	356	442	542	654	
	BL	---	---	---	1.5	1.5	1.5	1.5	3.0	---	1.5	1.5	1.5	1.5	3.0	3.0	3.0	4.5	
32'	TL	---	---	---	---	99	134	175	225	---	---	162	219	288	369	463	571	694	
	LL	---	---	---	---	82	109	141	179	---	---	135	179	232	294	366	448	542	
	BL	---	---	---	---	1.5	1.5	1.5	3.0	---	---	1.5	1.5	1.5	3.0	3.0	3.0	4.5	
34'	TL	---	---	---	---	81	110	144	186	---	---	132	180	237	304	383	473	576	
	LL	---	---	---	---	69	91	118	150	---	---	112	149	194	246	306	375	453	
	BL	---	---	---	---	1.5	1.5	1.5	1.5	---	---	1.5	1.5	1.5	3.0	3.0	3.0	4.5	
36'	TL	---	---	---	---	---	91	120	154	---	---	---	148	196	253	319	396	483	
	LL	---	---	---	---	---	77	100	126	---	---	---	126	163	207	258	317	383	
	BL	---	---	---	---	---	1.5	1.5	1.5	---	---	---	1.5	1.5	1.5	3.0	3.0	3.0	
38'	TL	---	---	---	---	---	---	100	129	---	---	---	---	164	212	268	333	407	
	LL	---	---	---	---	---	---	85	108	---	---	---	---	139	176	220	270	327	
	BL	---	---	---	---	---	---	1.5	1.5	---	---	---	---	1.5	1.5	1.5	3.0	3.0	

(See Requirements for Use on page 23, Key and Example on page 34, and Notes on page 34 and this page)

Notes for Table 38: Allowable Roof Loads (plf) - 1.25 Load Duration Factor

- For practicality, allowable roof loads are omitted from the table when they exceed 3,000 and 6,000 pounds per lineal foot (plf) for the 3-1/8" and 5-1/8"-wide beams, respectively, and when a glued laminated timber's span-to-depth ratio exceeds 30.
- To determine allowable roof loads for 3- and 3-1/2"-wide glued laminated timber beams, multiply tabulated total loads (TL) and live loads (LL) for 3-1/8"-wide beams by 0.96 and 1.12, respectively. Then check the required bearing length (BL).
- To determine allowable roof loads for 5- and 5-1/2"-wide glued laminated timber beams, multiply the TL and LL values for 5-1/8" wide beams by 0.976 or 1.073, respectively. Then check the required bearing length (BL).

WHY? wood!

Wood products are the most environmentally responsible building material available, making them the GREEN choice.

Life cycle of wood building products



How Does Wood Reduce Carbon?

Wood products require less energy to manufacture – meaning fewer greenhouse gases, like CO₂. And trees use CO₂ to grow, changing greenhouse gases into the building blocks we know as wood. That's why wood products are increasingly being recognized as tools to combat climate change.

As trees grow, they remove and store carbon from the atmosphere.



Additional Resources

The Southern Forest Products Association offers a wide variety of helpful publications for design-build professionals. The titles listed below are available online in PDF. Visit SouthernPine.com to download and see a listing of all publications.

Southern Pine Use Guide (#200)

grade descriptions, design values, applications, specification guidelines

Southern Pine Maximum Spans for Joists & Rafters (#202)
span tables, design criteria

Raised Wood Floor Foundations (#411)

foundation types, construction details, floor framing spans, cost-saving strategies

Pressure-Treated Southern Pine (#300)

preservative types, standards, specifications, applications



Online PRODUCT LOCATOR

Sourcing Southern Pine products?

Visit the online Product Locator at

SouthernPine.com

to find SFPA member producers.



**SOUTHERN
PINE**

*the versatile
building
material*



6660 Riverside Drive, Suite 212 Metairie, LA 70003
504/443-4464 • mail@sfpa.org

SouthernPine.com
SouthernPineDecks.com
RaisedFloorLiving.com